

Schwenkbereich  $\pm 115^\circ$   
Swivel area  $\pm 115^\circ$

Spannzange / collet ER25 DIN6499  
Spannbereich / clamping range: 1,0 - 16,0

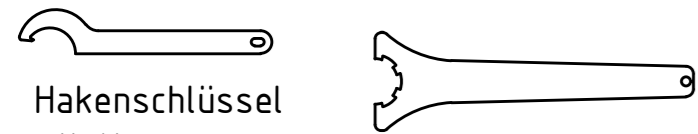
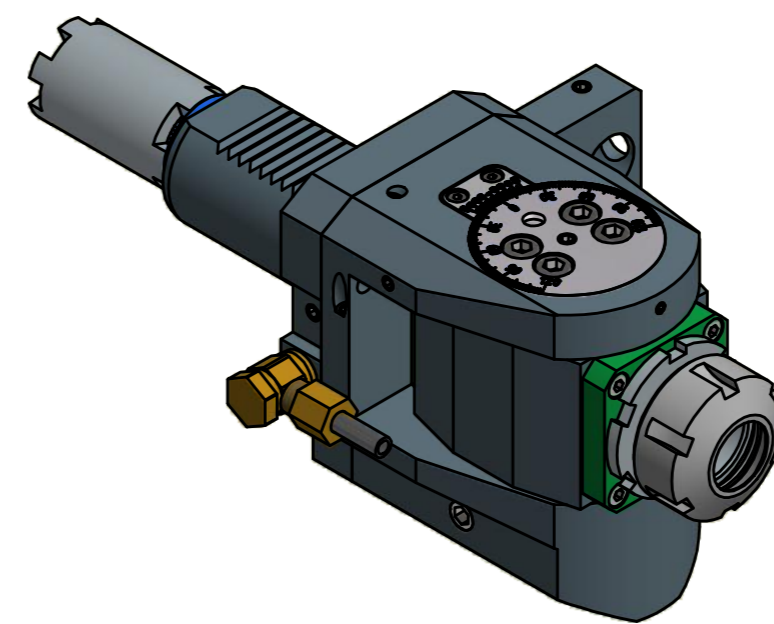
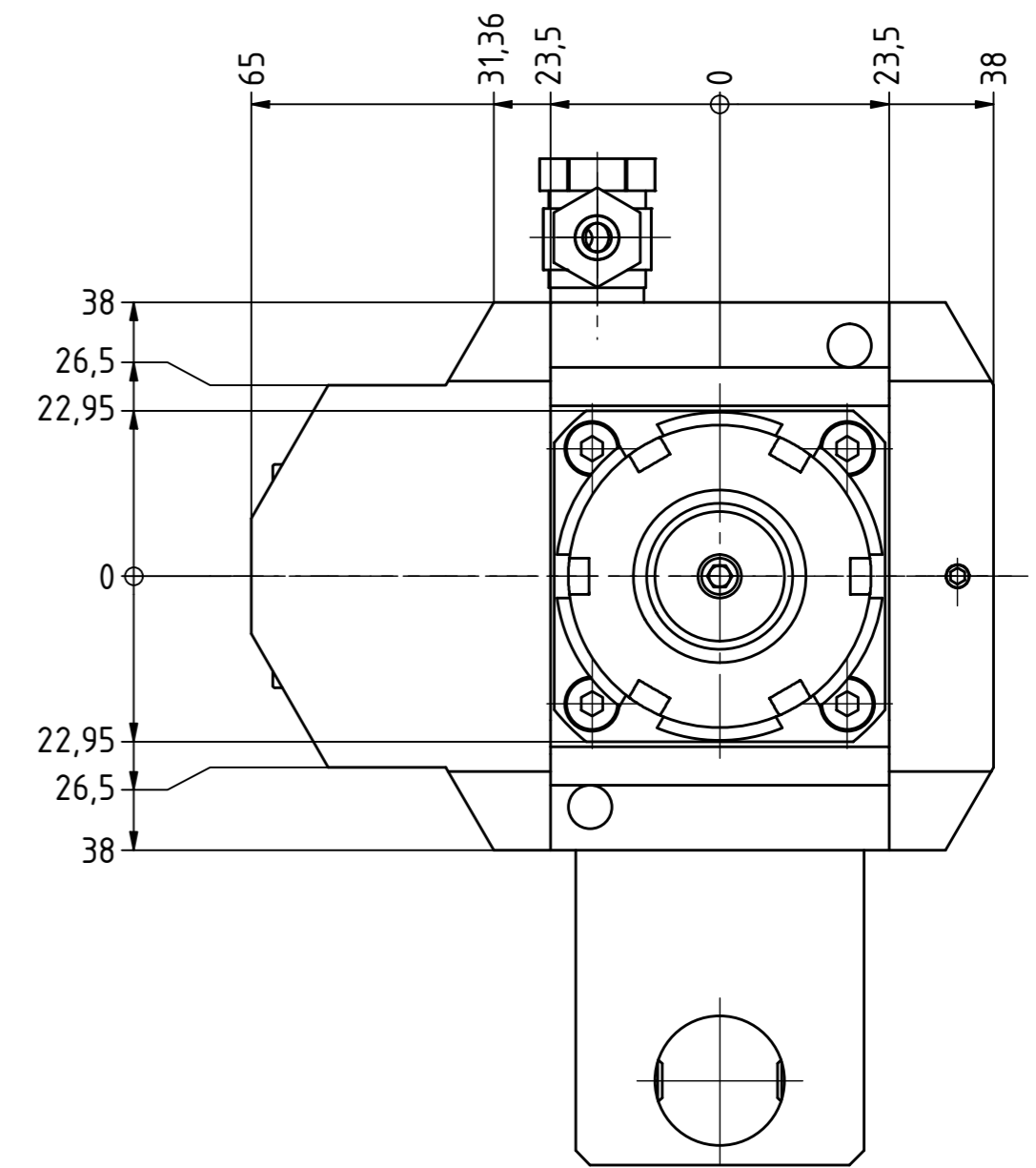

Hakenschlüssel  
mit Nase  
Hook wrench with  
nose end  
DIN1810 A 45x50

Spannzangenschlüssel  
Clamping wrench  
225

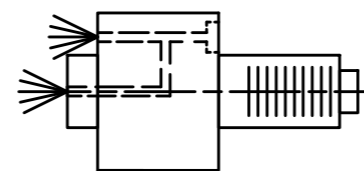

Innen- und Aussenkuehlung / Inside and outside coolant supply  
Kuehlmittelfiltrierung-50µ / coolant filtration-50µ

Bemerkung - Note Für Trockenlauf geeignet! Use without coolant fluid allowed!	Technische Daten - technical data Weight = 5.276 [kg]
	Torque max. (M1/M2) = 20 / 20 [Nm]
	Speed max. (n1/n2) = 6000 / 6000 [1/min]
	Gear ratio (i)=n1:n2 = 1:1
	Pressure (pmax) = 70 [bar]

Benennung - Title  
Schwenkkopf  
Swivel head

Copyright **EWS Tool Technologies**  
Weitergabe und Vervielfältigung dieser Unterlage,  
Verwertung und Mitteilung ihres Inhalts nicht  
gestattet, soweit nicht ausdrücklich zugestanden.  
Zu widerhandlungen verpflichten zu Schadenersatz.

<b>EWS</b> <small>Tool Technologies</small> EWS Weigle GmbH & Co. KG Maybachstr. 1 D-73066 Uhingen www.ews-tool.de	Technische Änderungen vorbehalten! Subject to technical modifications! IDENT: D-EWS-066832	REV: -/D MNR.
	Nr. - No. 63.4025HAASSL40IKD	144433

