

Spannzange / collet ER40 DIN6499
Spannbereich / clamping range: 3,0 - 26,0

Gewindebohrzange / tapping collet
ET-1-40 M6-M16

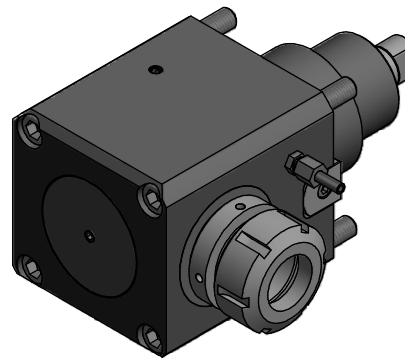
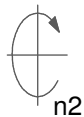

Hakenschlüssel
mit Zapfen
Hook wrench
with fixed pin
DIN1810 B 58x62

Spannzangenschlüssel
Clamping wrench
240

Copyright **EWS Tool Technologies**
Weitergabe und Vervielfältigung dieser Unterlage,
Verwertung und Mittelung ihres Inhalts nicht
gestattet, soweit nicht ausdrücklich zugestanden.
Zu widerhandlungen verpflichten zu Schadenersatz.

Bemerkung - Note

Technische Daten - Technical data

Weight = 13.328 [kg]
Torque max. (M1/M2) = 80 / 80 [Nm]
Speed max. (n1/n2) = 4.000 / 4.000 [1/min]
Gear ratio (i)=n1:n2 = 1:1

Benennung - Title

Radial Bohr und Fräskopf
Radial drilling and milling head

EWS EWS Werkzeug GmbH & Co. KG
Tool Technologies D-72084 Löhningen
www.ewstool.de

Nr. - No.
60.75401809GLX80

Technische Änderungen vorbehalten!
Subject to technical modifications!
IDENT: DEWS021669



REV: -/B
PBR

144425

QR