

Schwenkbereich $\pm 115^\circ$
Swivel area $\pm 115^\circ$

Spannzange / collet ER25 DIN6499
Spannbereich / clamping range: 1,0 - 16,0

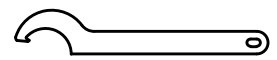

Hakenschlüssel
mit Nase

Hook wrench with
nose end

DIN1810 A 45x50

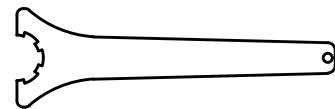

Spannzangenschlüssel
Clamping wrench

225

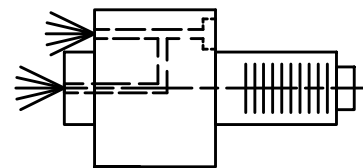

Innen- und Aussenkuehlung / Inside and outside coolant supply
Kuehlmittelfiltrierung-50 μ / coolant filtration-50 μ

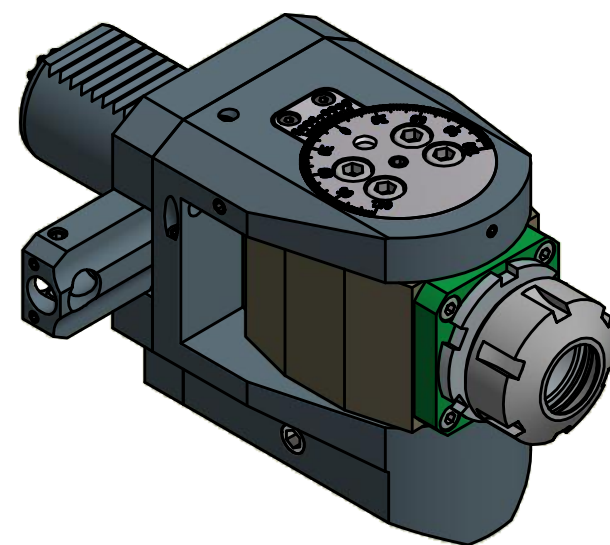

Copyright **EWS Tool Technologies**
Weitergabe und Vervielfaeltigung dieser Unterlage,
Verwertung und Mitteilung ihres Inhalts nicht
gestattet, soweit nicht ausdruercklich zugestanden.
Zuwaiderhandlungen verpflichten zu Schadenersatz.

Bemerkung - Note
Für Trockenlauf geeignet!
Use without coolant fluid allowed!

Technische Daten - technical data
Weight = 4.841 [kg]
Torque max. (M1/M2) = 20 / 20 [Nm]
Speed max. (n1/n2) = 6000 / 6000 [1/min]
Gear ratio (i)=n1:n2 = 1:1
Pressure (pmax) = 70 [bar]

Benennung - Title
Schwenkkopf
Swivel head

EWS
Tool Technologies
EWS Weigele GmbH & Co. KG
Maybachstr. 1
D-73066 UHINGEN
www.ews-tools.de

Technische Aenderungen vorbehalten!
Subject to technical modifications!

IDENT: D-EWS-066712

Nr. - No.

63.40255482IKD

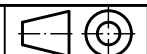

REV: -/C

MNR.

144420

QR