

Spannzange / Collet ER16 DIN6499
 Spannbereich / Clamping range: 1,0 - 10,0

Gewindebohrzange / Tapping Collet
 ET-1-16 M1-M6

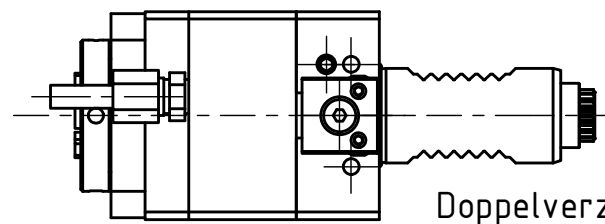

Doppelverzahnung Lizenz Traub
 double tooth system licence Traub

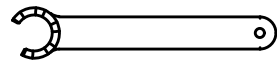

Spannzangenschlüssel für
 innenliegende Mutter
 Clamping wrench for
 internal collet
 216AX

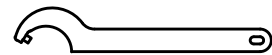

Hakenschlüssel
 mit Zapfen
 Hook wrench
 with fixed pin
 DIN1810 B 40x42

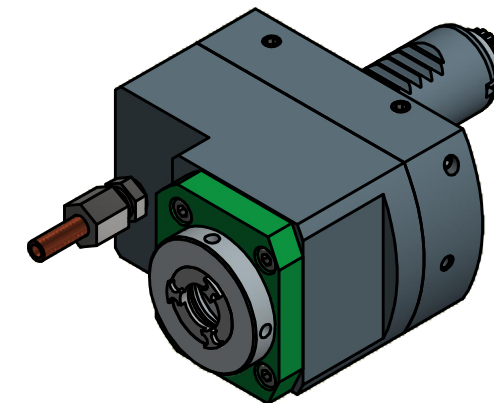

Copyright **EWS Tool Technologies**
 Weitergabe und Vervielfältigung dieser Unterlage,
 Verwertung und Mitteilung ihres Inhalts nicht
 gestattet, soweit nicht ausdrücklich zugestanden.
 Zuwiderhandlungen verpflichten zu Schadenersatz.

Bemerkung - Note

Technische Daten - technical data

Benennung - Title

Weight = 2.170 [kg]
 Torque max. (M1/M2) = 24 / 12 [Nm]
 Speed max. (n1/n2) = 6000 / 12000 [1/min]
 Gear ratio (i)=n1:n2 = 1:2

Axial Bohr u. Fräskopf achsversetzt
Ax. drill. and mill. head offset



Nr. - No.

50.25165480RLI1M

EWS Weigle GmbH & Co. KG
 Maybachstr. 1
 D-73066 UHINGEN
 www.ews-tools.de

Technische Änderungen vorbehalten!
 Subject to technical modifications!

IDENT: D-EWS-082011

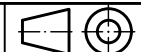

REV: -/A

MNR.

111883

