

Spannzange / collet ER32 DIN6499
Spannbereich / clamping range: 2,0 - 20,0

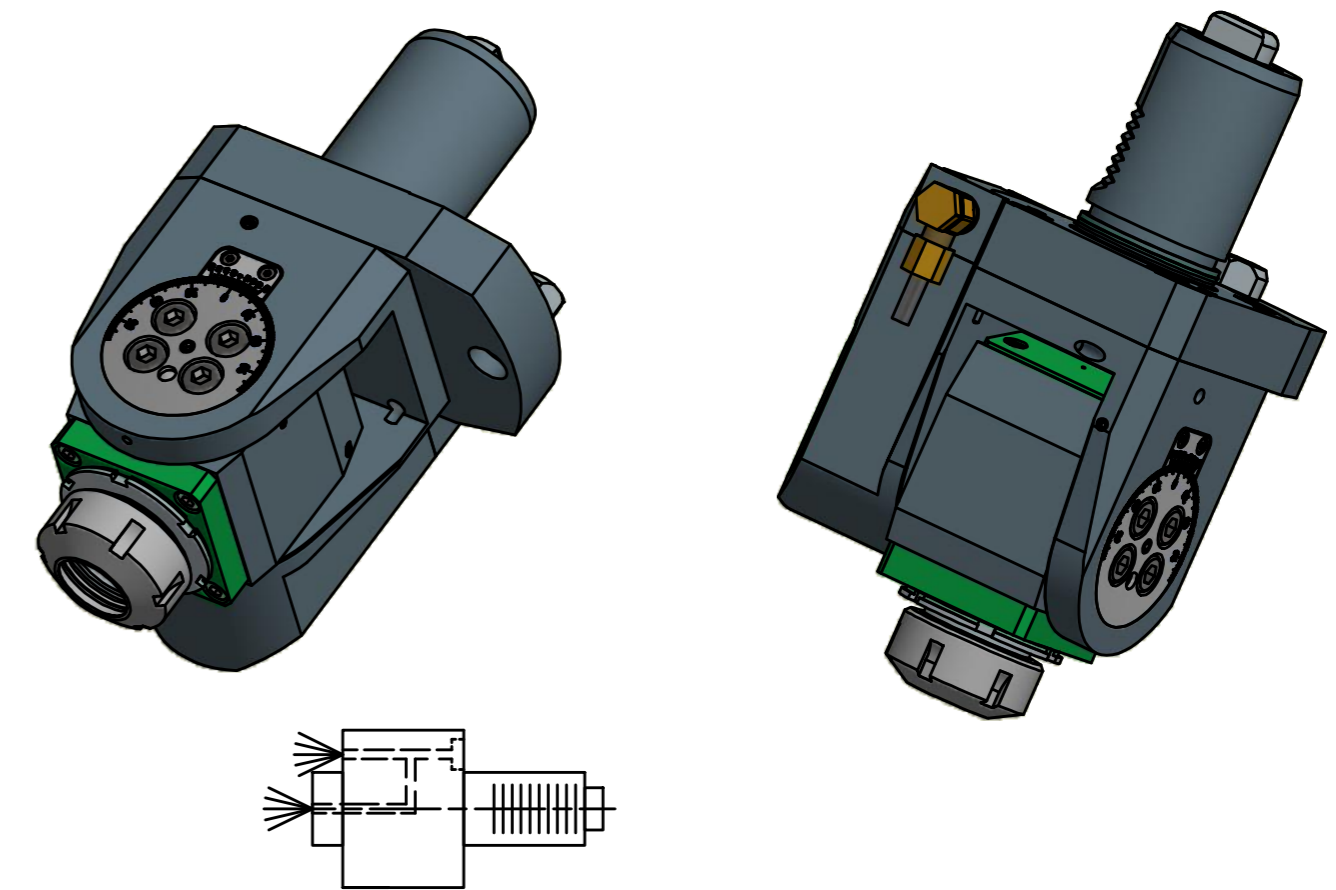
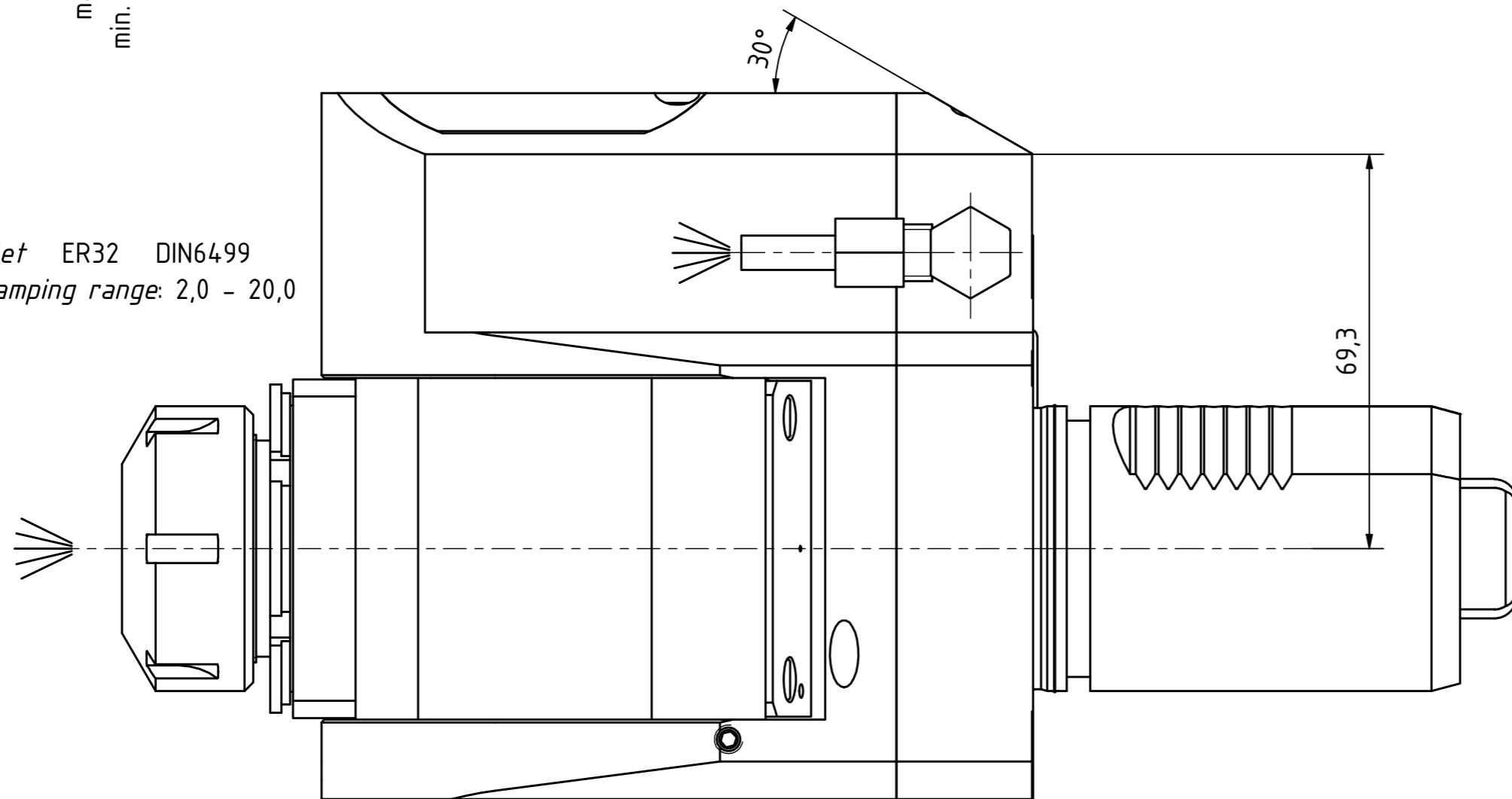

Innen- und Aussenkuehlung / Inside and outside coolant supply
Kuehlmittelfiltrierung-50 μ / coolant filtration=50 μ

Copyright **EWS Tool Technologies**
Weitergabe und Vervielfaeltigung dieser Unterlage,
Verwertung und Mitteilung ihres Inhalts nicht
gestattet, soweit nicht ausdruercklich zugestanden.
Zuwaerhandlungen verpflichten zu Schadenersatz.

Hakenschlüssel
mit Nase
Hook wrench with
nose end
DIN1810 A 58x62

Spannzangenschlüssel
Clamping wrench
232

Eine Nachbarstation ist nicht verwendbar!
One neighbour station is not useable!

Bezeichnung - Title	Technische Daten - technical data
Für Trockenlauf geeignet! Use without coolant fluid allowed!	Weight = 8.985 [kg] Torque max. (M1/M2) = 50 / 50 [Nm] Speed max. (n1/n2) = 4000 / 4000 [1/min] Gear ratio (i)=n1:n2 = 1:1 Pressure (pmax) = 70 [bar]

Schwenkkopf
Swivel head

EWS Tool Technologies		EWS Weigle GmbH & Co. KG Maybachstr. 1 D-73066 Uhlingen www.ews-tools.de		Technische Änderungen vorbehalten! Subject to technical modifications!	
Nr. - No.	63.5032SQT28IKD	IDENT:	D-EWS-066070	REV:	-/C
				MNR.	144557

