

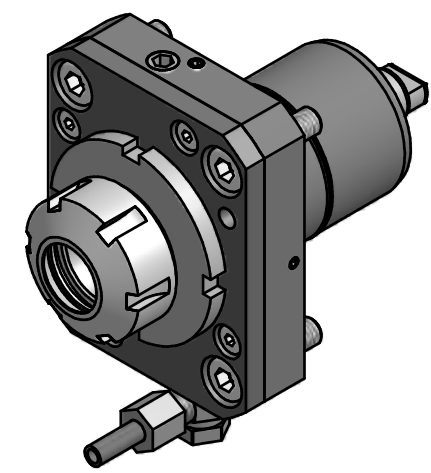

Spannzange / collet ER25 DIN6499
 Spannbereich / clamping range: 1,0 - 16,0

Gewindebohrzange / tapping collet
 ET-1-25 M3-M10

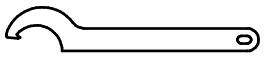

-  Hakenschlüssel mit Nase
Hook wrench with nose end
DIN1810 A 40x42
-  Spannzangenschlüssel
Clamping wrench
225

Copyright **EWS Tool Technologies**
 Weitergabe und Vervielfältigung dieser Unterlage, Verwertung und Mitteilung ihres Inhalts nicht gestattet, soweit nicht ausdrücklich zugestanden. Zuwiderhandlungen verpflichten zu Schadenersatz.

Bemerkung - Note	Technische Daten - technical data M1 / M2 = 32 / 32 Nm n1 / n2 = 6000 / 6000 1/min i (N1:N2) = 1:1	Benennung - Title Axial Bohr und Fräskopf <i>Axial drilling and milling head</i>	name	date	Technische Änderungen vorbehalten! Subject to technical modifications!	 Nr. 40.4525BND1809 DIN A3	
			drawing	M.Wiesenberg			24.03.2015
			 EWS Weigete GmbH & Co. KG Maybachstr. 1 D-73066 Uhingen Tel. +49(0)7161/93040-100		MNR: 143872	IDENT: D-EWS-066868 A	Blatt - page 1 (1)