

Doppelverzahnung Lizenz Traub  
double tooth system licence Traub

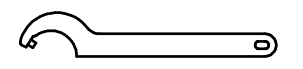
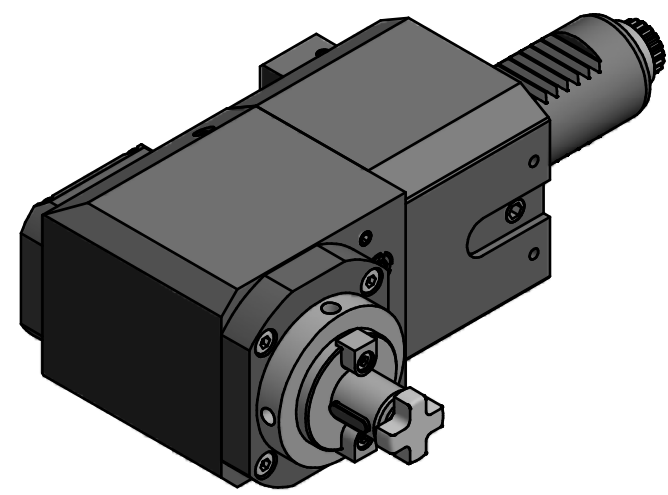

Hakenschlüssel  
mit Zapfen  
Hook wrench  
with fixed pin  
DIN1810 B 45x50

Copyright **EWS Tool Technologies**  
Weitergabe und Vervielfaeltigung dieser Unterlage,  
Verwertung und Mitteilung ihres Inhalts nicht  
gestattet, soweit nicht ausdruuecklich zugestanden.  
Zuwaiderhandlungen verpflichten zu Schadenersatz.

<p>Bemerkung - Note</p>	<p>Technische Daten - technical data</p> <p>Weight = 4.140 [kg] Torque max. (M1/M2) = 25 / 25 [Nm] Speed max. (n1/n2) = 8000 / 8000 [1/min] Gear ratio (i)=n1:n2 = 1:1</p>	<p>Benennung - Title</p> <p><b>Radial Fräskopf</b> <b>Radial milling head</b></p>	<p><b>EWS</b> Tool Technologies</p> <p>EWS Weigele GmbH &amp; Co. KG Maybachstr. 1 D-73066 Uhingen www.ews-tools.de</p> <p>Nr. - No. <b>62.3016LCTXRL</b></p>	<p>Technische Aenderungen vorbehalten! Subject to technical modifications!</p> <p>IDENT: D-EWS-004051</p>	<p>REV: A/-</p> <p>MNR. <b>111854</b></p>	<p>QR</p>
-------------------------	--	---	---	---	---	-----------