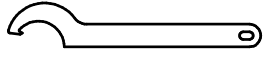
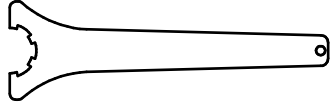

-  Hakenschlüssel mit Nase
Hook wrench with nose end
DIN1810 A 40x42
-  Spannzangenschlüssel
Clamping wrench
225

Innen- und Aussenkuehlung / Inside and outside coolant supply
Kein Trockenlauf / No dry run
Kuehlmittelfiltrierung <math>< 50\mu</math> / coolant filtration <math>< 50\mu</math>

Spannzange / collet ER25 DIN6499
Spannbereich / clamping range: 1,0 - 16,0

Copyright **EWS Tool Technologies**
Weitergabe und Vervielfaeltigung dieser Unterlage, Verwertung und Mitteilung ihres Inhalts nicht gestattet, soweit nicht ausdruercklich zugestanden. Zuwiderhandlungen verpflichten zu Schadenersatz.

Bemerkung - Note Nicht ohne Kuehlmittel betreiben! Not for use without coolant-fluid!	Technische Daten - technical data M1 / M2 = 32 / 32 Nm n1 / n2 = 6000 / 6000 1/min i (N1:N2) = 1:1 pmax = 25 bar	Benennung - Title Axial Bohr und Fräskopf <i>Axial drilling and milling head</i>	name	date	Technische Aenderungen vorbehalten! Subject to technical modifications!	 DIN A3
			drawing	M.Wiesenberg		
			 EWS Weigle GmbH & Co. KG Maybachstr. 1 D-73066 Uhingen Tel. +49(0)7161/93040-100		Nr. 40.4525BND18091K	
			MNR: 144534		IDENT: D-EWS-066917 A	Blatt - page 1 (1)