

Spannzange / collet ER50 DIN6499
 Spannbereich / clamping range: 6,0 - 34,0

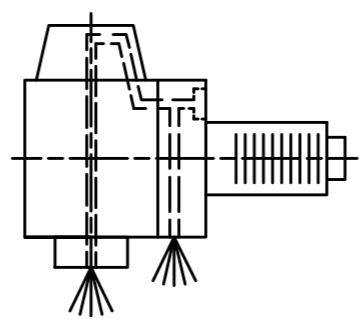

Innen- und Aussenkühlung / Inside and outside coolant supply
 Kühlmittelfiltrierung-50µ / coolant filtration-50µ

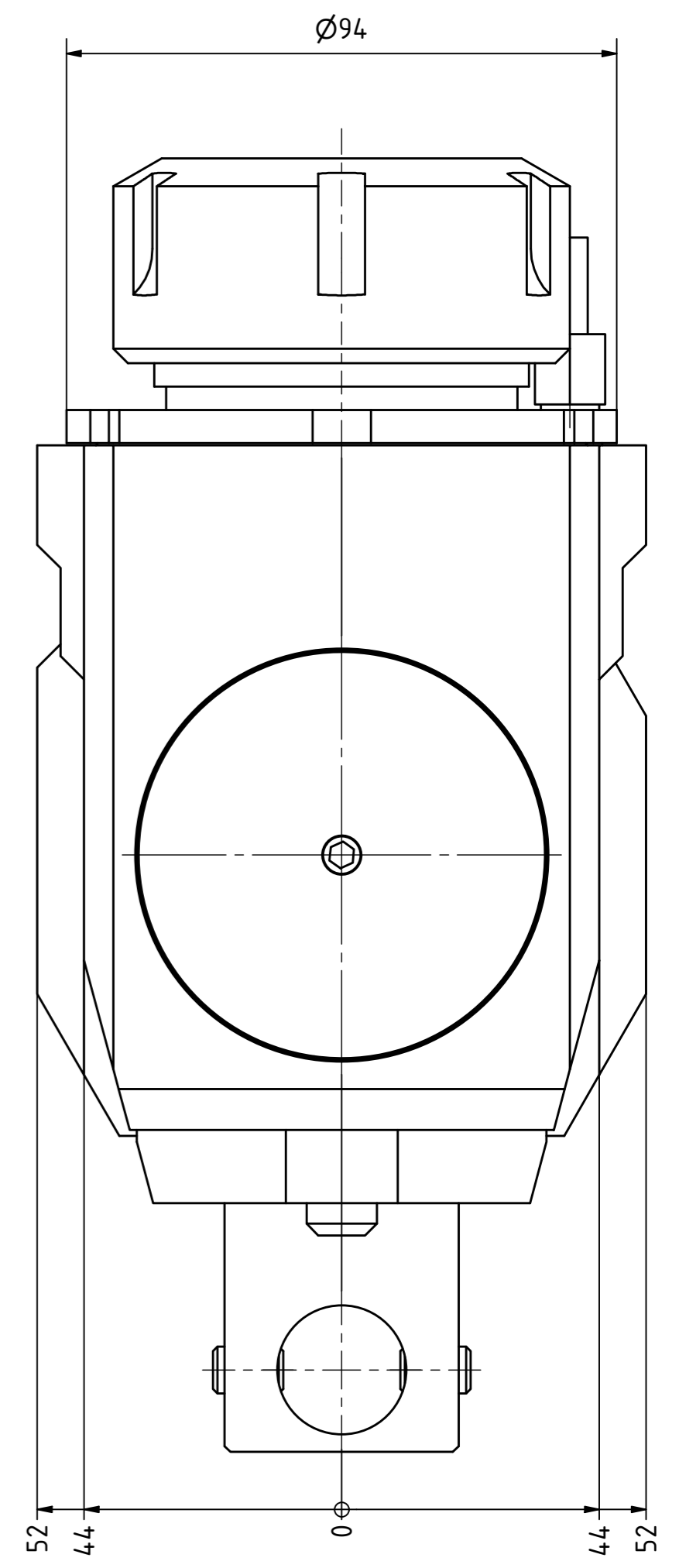
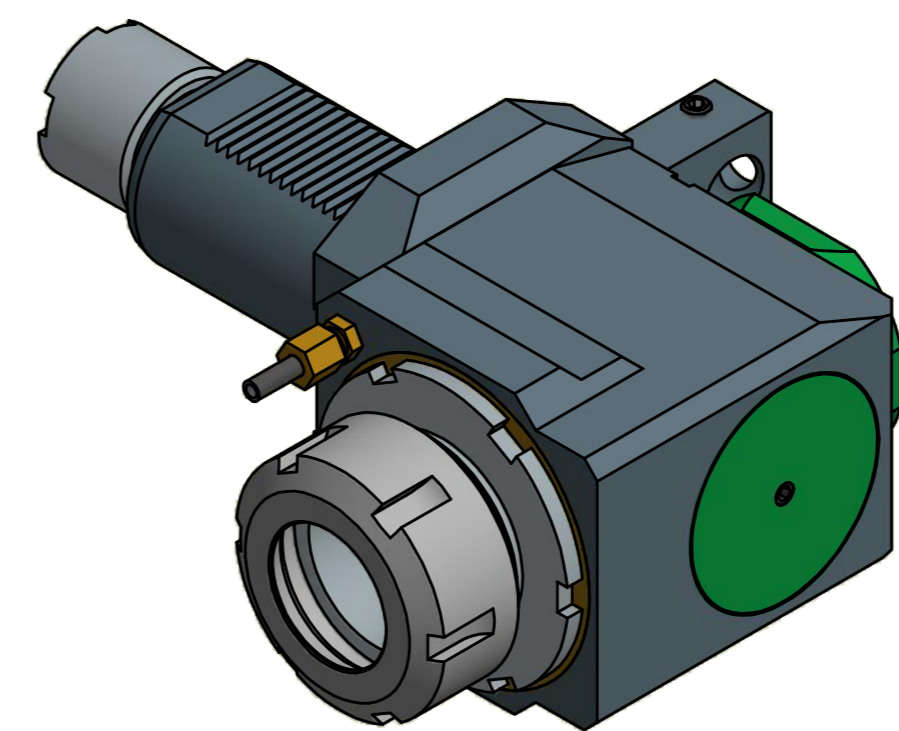
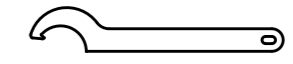
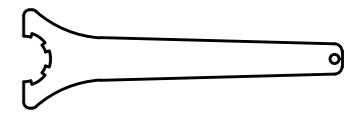

-  Hakenschlüssel mit Nase
Hook wrench with nose end
DIN1810 A 80x90
-  Spannzangenschlüssel
Clamping wrench
250

Copyright **EWS Tool Technologies**
 Weitergabe und Vervielfältigung dieser Unterlage, Verwertung und Mitteilung ihres Inhalts nicht gestattet, soweit nicht ausdrücklich zugestanden. Zuwiderhandlungen verpflichten zu Schadenersatz.

Bemerkung - Note
 Für Trockenlauf geeignet!
 Use without coolant fluid allowed!

Technische Daten - technical data
 Weight = 11,486 [kg]
 Torque max. (M1/M2) = 160 / 160 [Nm]
 Speed max. (n1/n2) = 3000 / 3000 [1/min]
 Gear ratio (i)=n1:n2 = 1:1
 Pressure (pmax) = 70 [bar]

Benennung - Title
Radial Bohr und Fräskopf
 Radial drilling and milling head

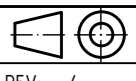
 EWS <small>Tool Technologies</small> <small>EWS Weigle GmbH & Co. KG Maybachstr. 1 D-73066 Uhlingen www.ews-tools.de</small>	<small>Technische Änderungen vorbehalten!</small> <small>Subject to technical modifications!</small> IDENT: D-EWS-128303	 REV: -/- MNR.
	Nr. - No. 60.6050LB45LIKD	112136