

min. 73  
max. 76,6

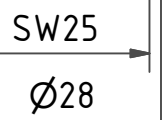

Spannzange / Collet ER16 DIN6499  
Spannbereich / Clamping range: 1,0 - 10,0

Gewindebohrzange / Tapping Collet  
ET-1-16 M1-M6

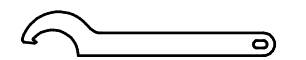
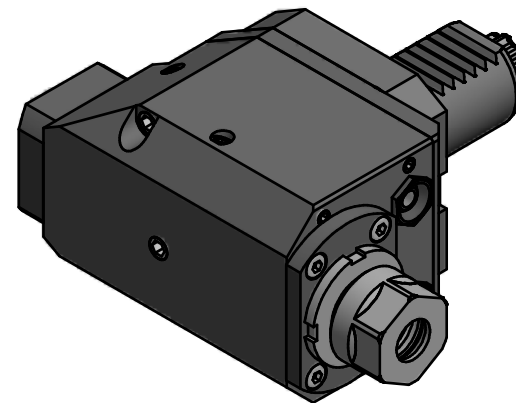
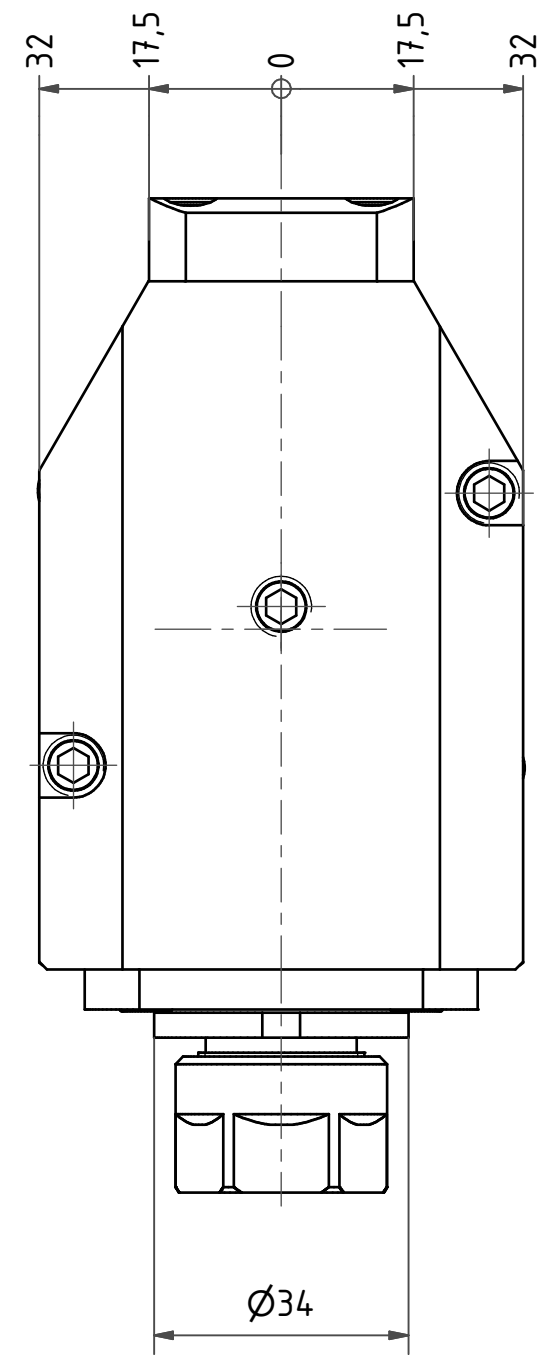
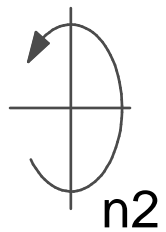

Hakenschlüssel  
mit Nase  
Hook wrench with  
nose end  
DIN1810 A 34x36

Copyright **EWS Tool Technologies**  
Weitergabe und Vervielfältigung dieser Unterlage,  
Verwertung und Mitteilung ihres Inhalts nicht  
gestattet, soweit nicht ausdrücklich zugestanden.  
Zuwiderhandlungen verpflichten zu Schadenersatz.

Bemerkung - Note

Technische Daten - technical data

Weight = 2.974 [kg]  
Torque max. (M1/M2) = 15 / 5 [Nm]  
Speed max. (n1/n2) = 6000 / 18000 [1/min]  
Gear ratio (i)=n1:n2 = 1:3

Benennung - Title

Radial Bohr und Fräskopf  
Radial drilling and milling head

**EWS**  
Tool Technologies

Nr. - No.  
60.30165482RI13

Technische Änderungen vorbehalten!  
Subject to technical modifications!

IDENT: D-EWS-001582



REV: B/-

MNR.

111089

QR