

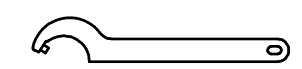

Spannzange / collet ER25 DIN6499  
 Spannbereich / clamping range: 1,0 - 16,0

Gewindebohrzange / tapping collet  
 ET-1-25 M3-M10

-  Hakenschlüssel mit Zapfen  
Hook wrench with fixed pin  
DIN1810 B 45x50
-  Spannzangenschlüssel  
Clamping wrench  
225

Copyright **EWS Tool Technologies**  
 Weitergabe und Vervielfältigung dieser Unterlage, Verwertung und Mitteilung ihres Inhalts nicht gestattet, soweit nicht ausdrücklich zugestanden. Zuwiderhandlungen verpflichten zu Schadenersatz.

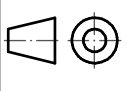
Bemerkung - Note  	Technische Daten - technical data M1 / M2= 50 /50 Nm n1 / n2 = 6000 /6000 1/min i (N1:N2) = 1:1	Benennung - Title <b>Axial Bohr u. Fräskopf achsversetzt</b> <b>Ax. drill. and mill. head offset</b>	<table border="1"> <tr> <th>name</th> <th>date</th> </tr> <tr> <td>drawing</td> <td>16.03.2007</td> </tr> </table>	name	date	drawing	16.03.2007	Technische Aenderungen vorbehalten! Subject to technical modifications! Nr. <b>50.4025MP620R</b>	 DIN A3
name	date								
drawing	16.03.2007								
			<b>EWS</b> EWS Weigete GmbH & Co. KG Maybachstr. 1 D-73066 Uhingen Tel. +49(0)7161/93040-100	MNR: 111779 IDENT: D-EWS-012401 A	Blatt - page 1 (1)				