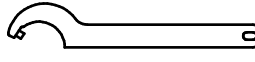
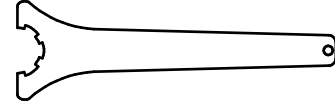

Spannzange / collet ER32 DIN6499  
 Spannbereich / clamping range: 2,0 - 20,0

-  Hakenschlüssel mit Zapfen  
Hook wrench with fixed pin  
DIN1810 B 45x50
-  Spannzangenschlüssel  
Clamping wrench  
232

Copyright **EWS Tool Technologies**  
 Weitergabe und Vervielfaeltigung dieser Unterlage,  
 Verwertung und Mitteilung ihres Inhalts nicht  
 gestattet, soweit nicht ausdrecklich zugestanden.  
 Zuwiderhandlungen verpflichten zu Schadenersatz.

Bemerkung - Note  
 Nicht ohne Kuehlmittel betreiben!  
 Not for use without coolant-fluid!

Technische Daten - technical data	
Weight	= 7.154 [kg]
Torque max. (M1/M2)	= 50 / 50 [Nm]
Speed max. (n1/n2)	= 6000 / 6000 [1/min]
Gear ratio (i)=n1:n2	= 1:1
Pressure (pmax)	= 70 [bar]

Benennung - Title  
**Radial Bohr und Fräskopf**  
**Radial drilling and milling head**

**EWS** Tool Technologies  
 EWS Weigel GmbH & Co. KG  
 Maybachstr. 1  
 D-73066 Uehingen  
 www.ews-tools.de

Nr. - No.  
**60.4032LT15RIK**

Technische Aenderungen vorbehalten! Subject to technical modifications!	
IDENT: D-EWS-011782	REV: -/-
MNR.	<b>111071</b>

