

Hakenschlüssel  
mit Nase  
Hook wrench with  
nose end  
DIN1810 A 68x75

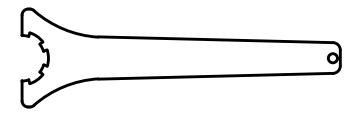

Spannzangenschlüssel  
Clamping wrench  
225



Highspeed



Tech  
Details

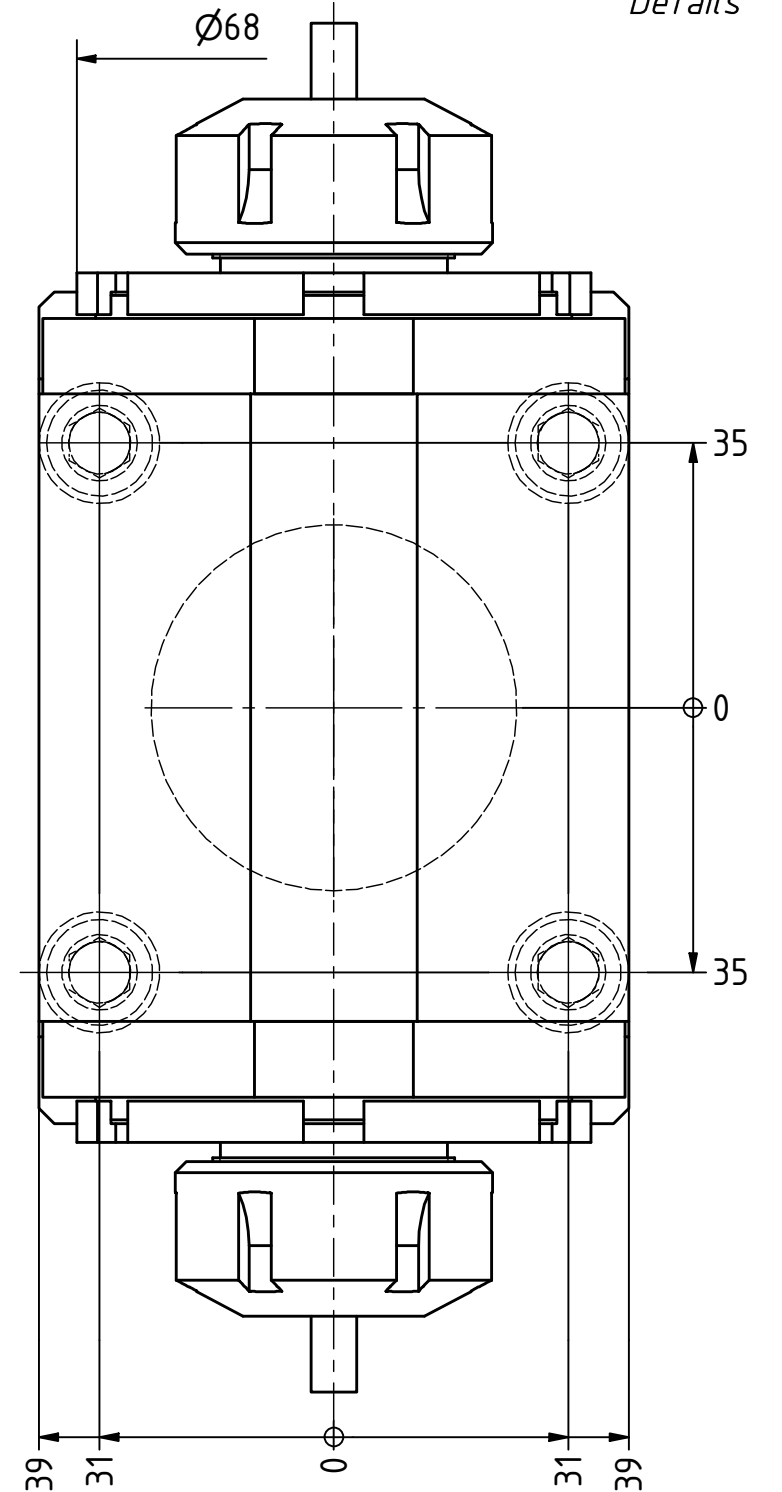
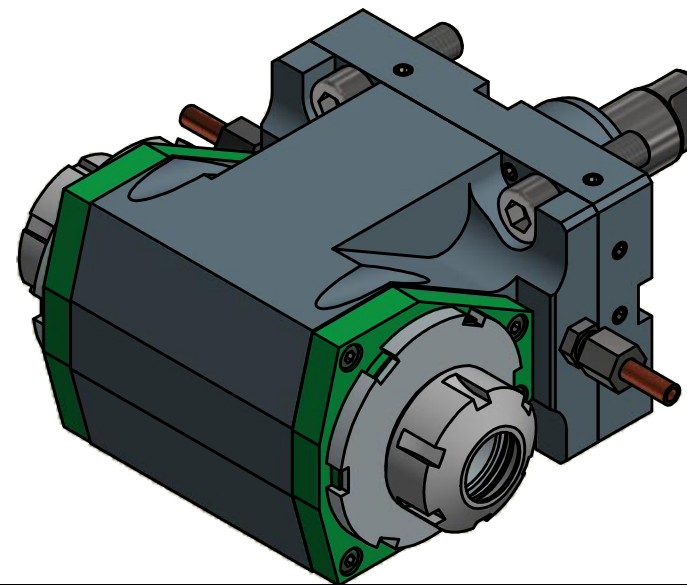

Copyright **EWS Tool Technologies**  
Weitergabe und Vervielfaeltigung dieser Unterlage,  
Verwertung und Mitteilung ihres Inhalts nicht  
gestattet, soweit nicht ausdrecklich zugestanden.  
Zuwiderhandlungen verpflichten zu Schadenersatz.

Bemerkung - Note
------------------

Technische Daten - technical data
Weight = 6.811 [kg]
Torque max. (M1/M2) = 32 / 32   32 [Nm]
Speed max. (n1/n2) = 12000 / 12000   12000 [1/min]
Gear ratio (i)=n1:n2 = 1:1   1:1

Benennung - Title
Radial Bohr und Fräskopf
Radial drilling and milling head

<b>EWS</b> Tool Technologies	EWS Weigele GmbH & Co. KG Maybachstr. 1 D-73066 UHINGEN www.ews-tools.de
Nr. - No.	60.4025DNZHSD12

Technische Aenderungen vorbehalten! Subject to technical modifications!
IDENT: DEWS121720
REV: -/D
MNR.
143348

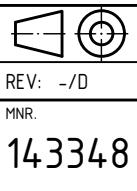

QR