

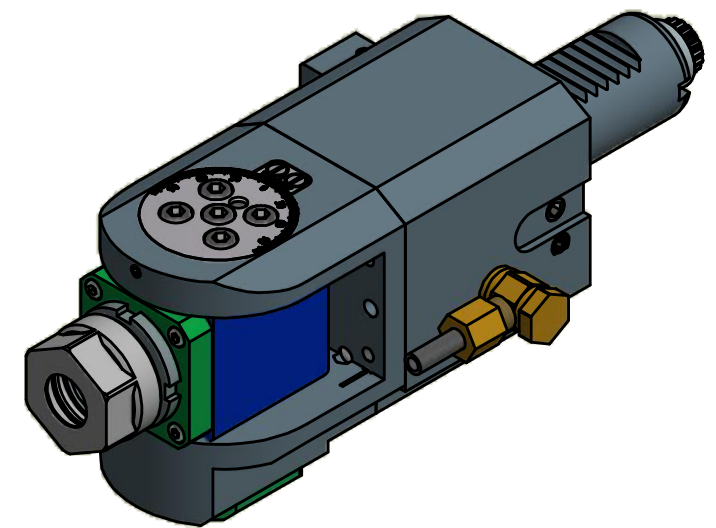

Spannzange / collet ER20 DIN6499
 Spannbereich / clamping range: 1,0 - 13,0

Gewindebohrzange / tapping collet
 ET-1-20 M2-M6

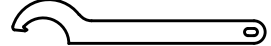

 Hakenschlüssel
 mit Nase
 Hook wrench with
 nose end
 DIN1810 A 34x36

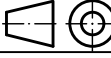
Copyright **EWS Tool Technologies**
 Weitergabe und Vervielfaeltigung dieser Unterlage,
 Verwertung und Mitteilung ihres Inhalts nicht
 gestattet, soweit nicht ausdrecklich zugestanden.
 Zuwiderhandlungen verpflichten zu Schadenersatz.

Bemerkung - Note	Technische Daten - technical data Weight = 4.294 [kg] Torque max. (M1/M2) = 16 / 16 [Nm] Speed max. (n1/n2) = 8000 / 8000 [1/min] Gear ratio (i)=n1:n2 = 1:1	Benennung - Title Schwenkkopf Swivel head	 EWS Weigele GmbH & Co. KG Maybachstr. 1 D-73066 UHINGEN www.ews-tools.de Nr. - No. 63.3020LCTX	Technische Aenderungen vorbehalten! Subject to technical modifications! IDENT: D-EWS-004074 MNR. 111410	 REV: -/A	
------------------	--	---	---	---	---	---