

max. Fraeser- $\varnothing 80$

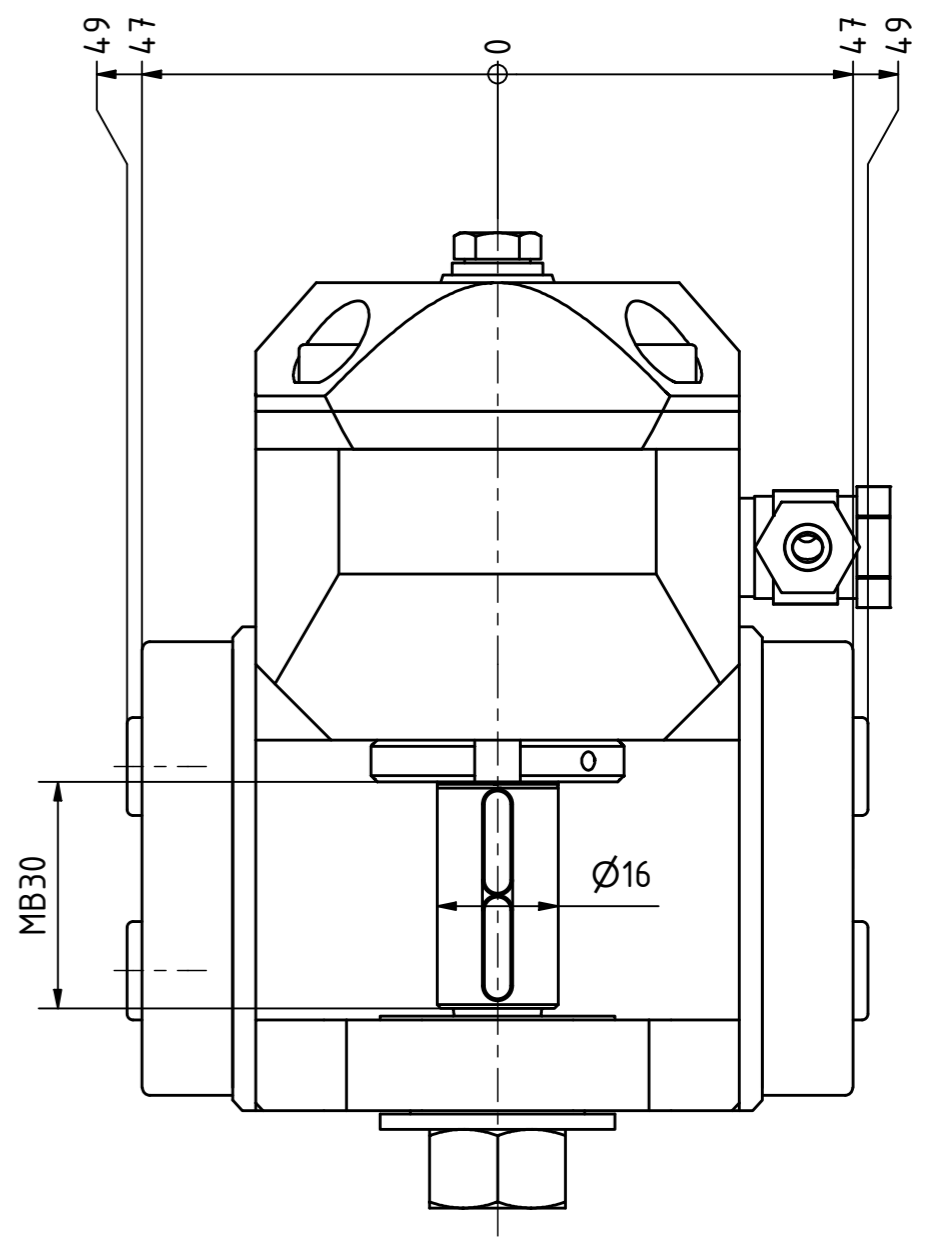

Fraeserwelle austauschbar
Spindle removable

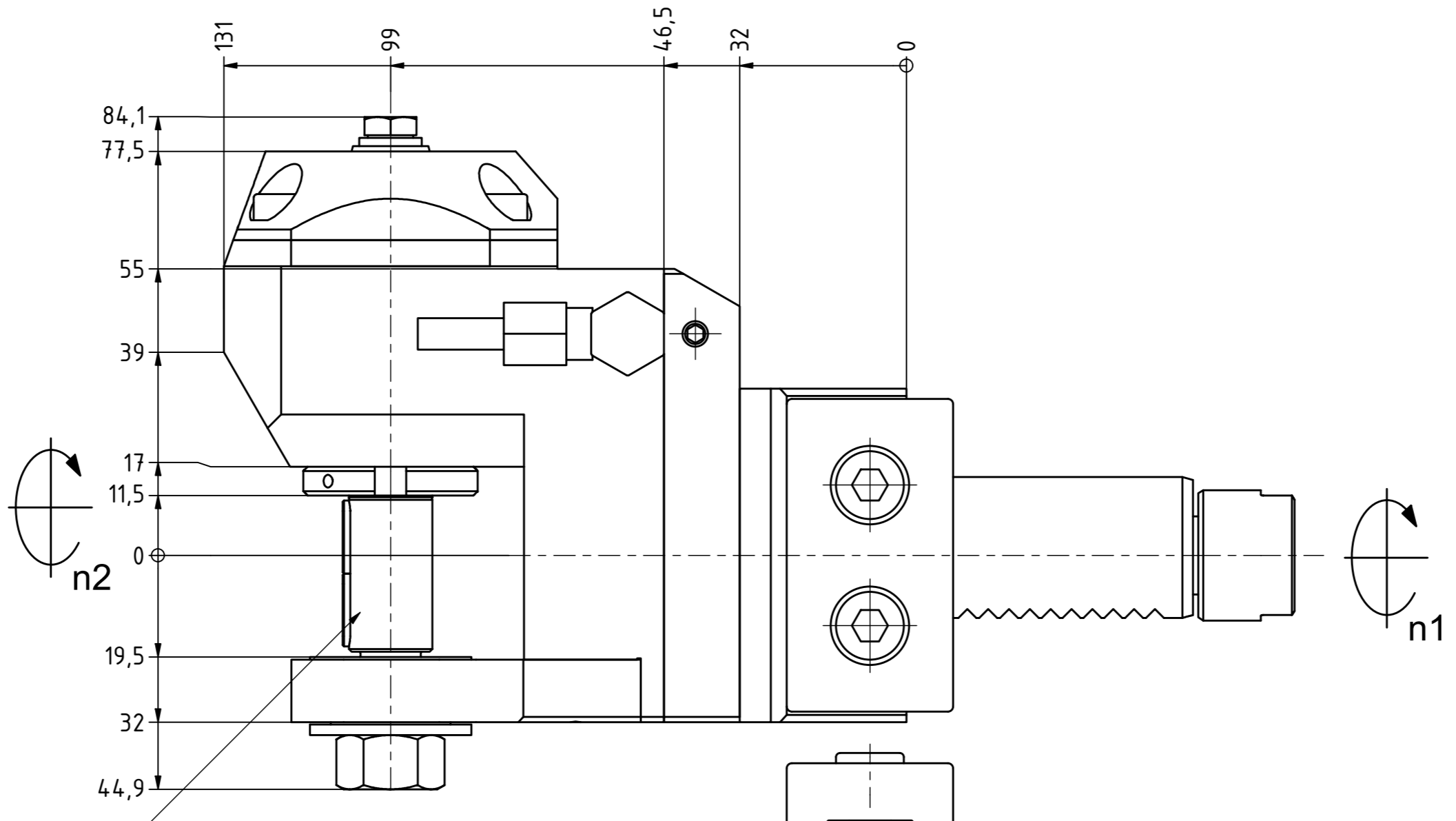
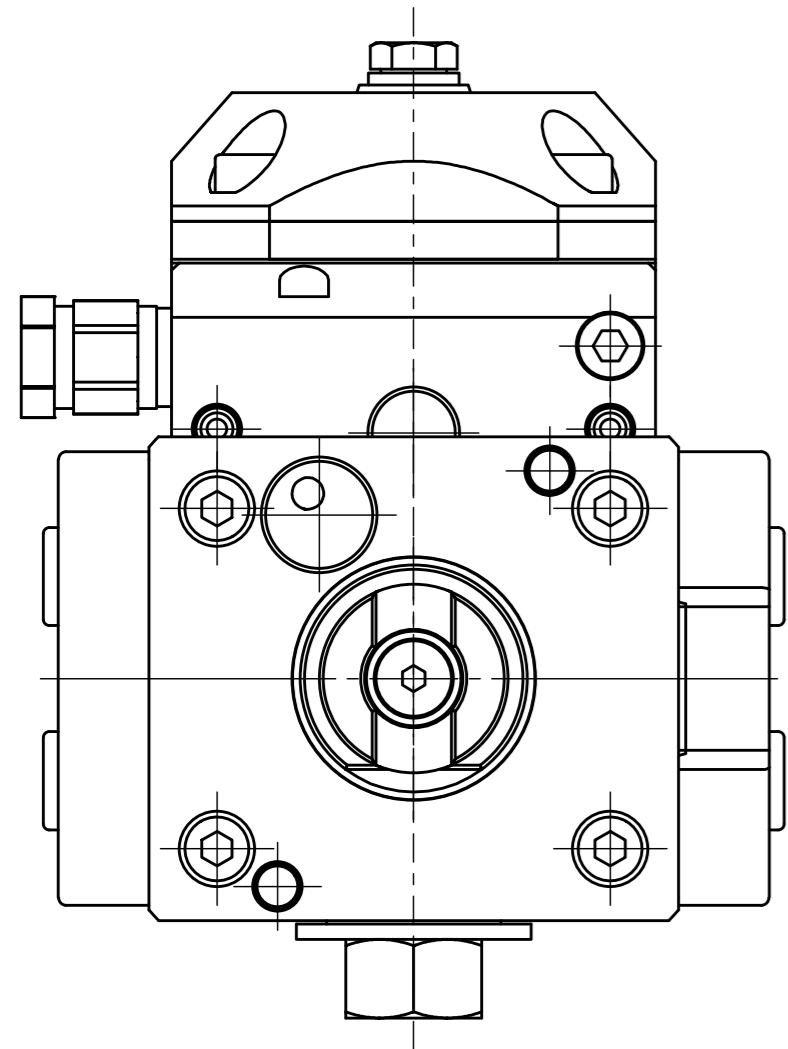
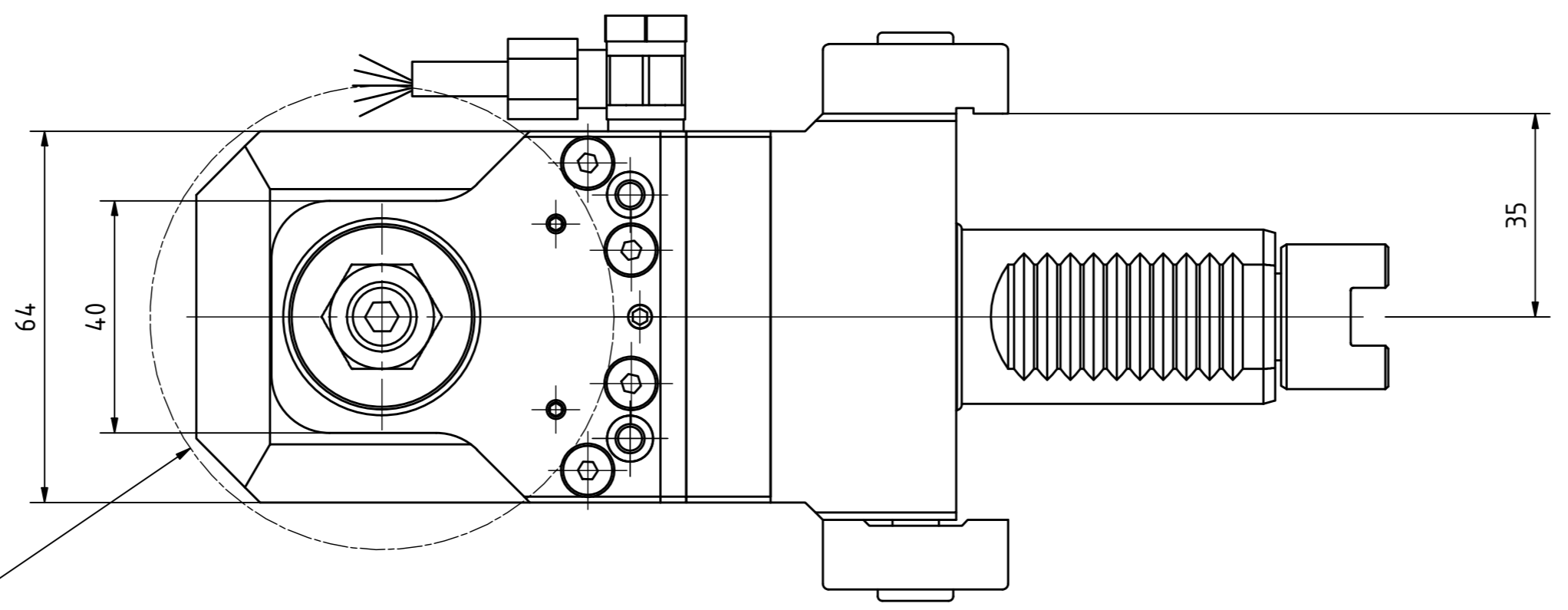
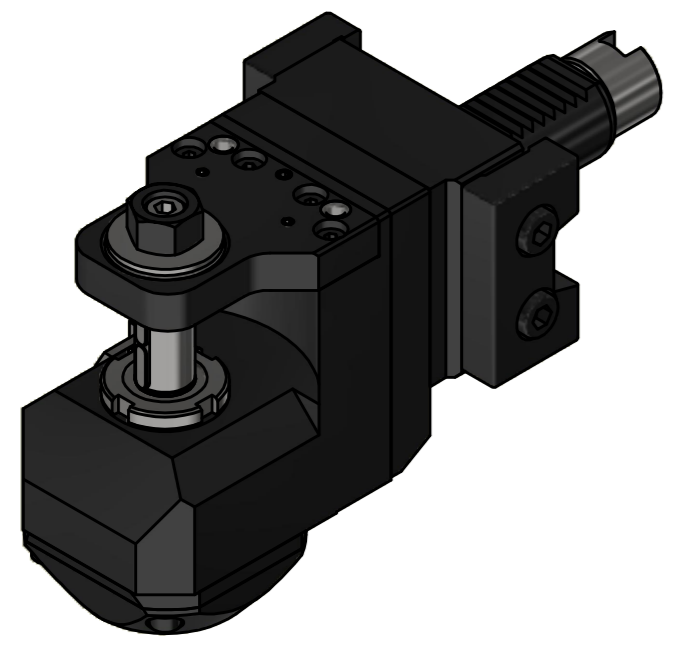

Benennung - Title	Technische Daten - Technical data
Scheibenfräserkopf	Weight = 4.775 [kg]
Radial saw milling head	Torque max. (M1/M2) = 20 / 60 [Nm]
	Speed max. (n1/n2) = 6000 / 2000 [1/min]
	Gear ratio (i)=n1:n2 = 3:1

Benennung - Title	Technische Änderungen vorbehalten! Subject to technical modifications!
64.3016G30013	IDENT: D-EWS-008652
	REV: -/B
	MNR. 110974

EWS Tool Technologies	EWS Weigle GmbH & Co. KG Maybachstr. 1 D-73066 Uhingen www.ews-tools.de
Nr. - No.	QR

Copyright **EWS Tool Technologies**
Weitergabe und Vervielfältigung dieser Unterlage,
Verwertung und Mitteilung ihres Inhalts nicht
gestattet, soweit nicht ausdrücklich zugestanden.
Zuwerhandlungen verpflichten zu Schadenersatz.