

6 | 5 | 4 | 3 | 2 | 1

D

C

B

A

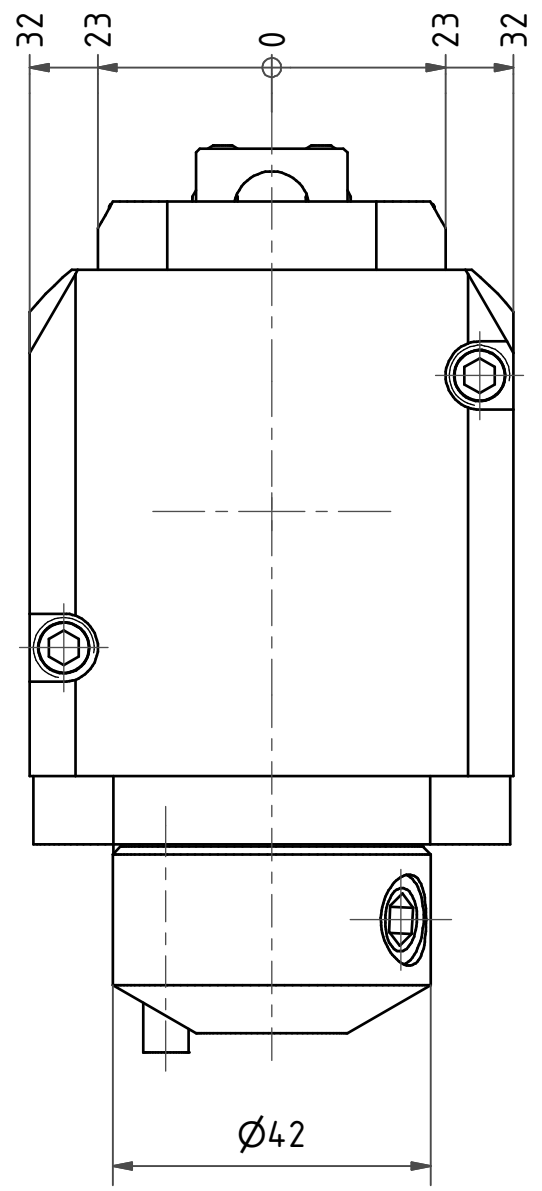
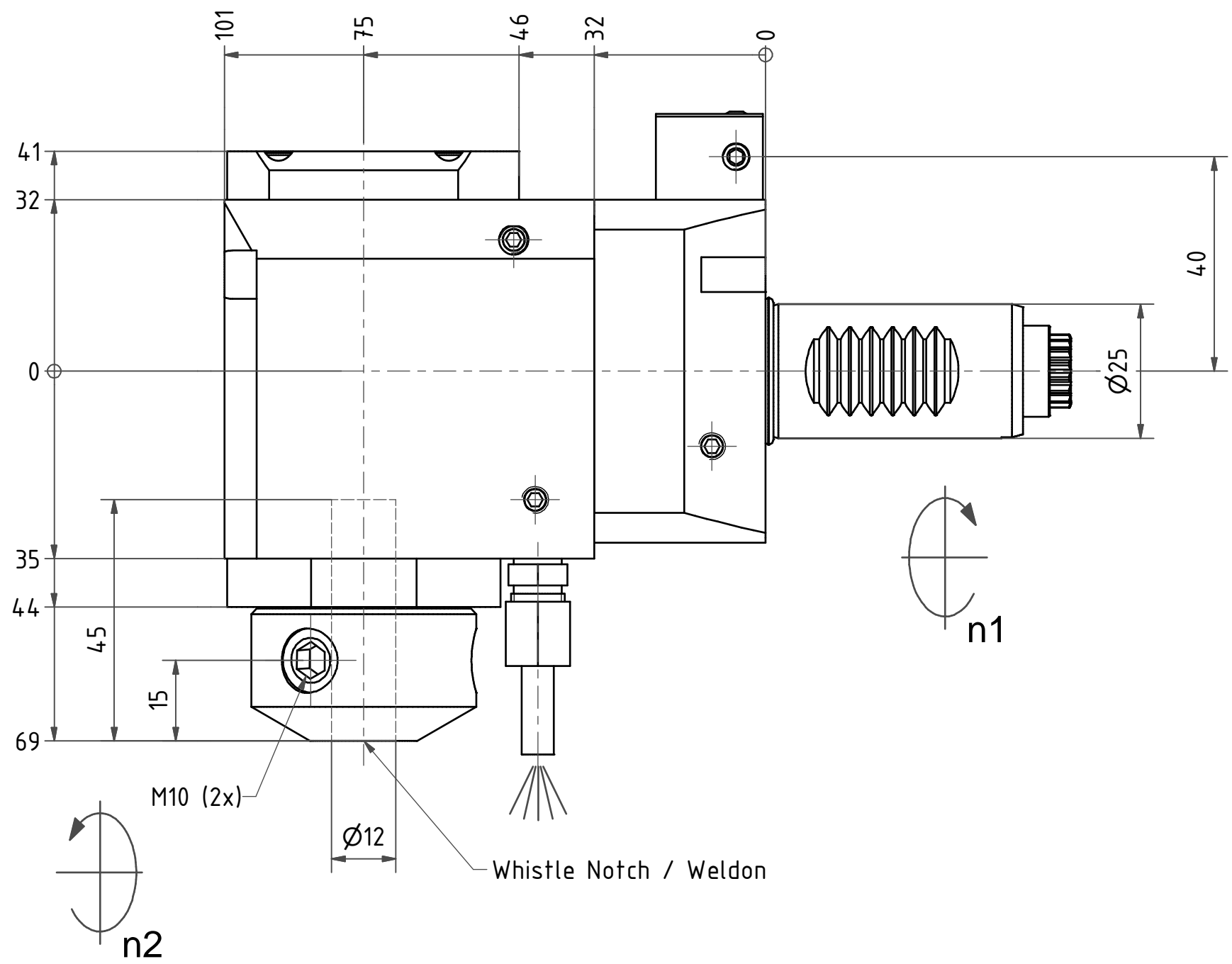

Doppelverzahnung Lizenz Traub
double tooth system licence Traub

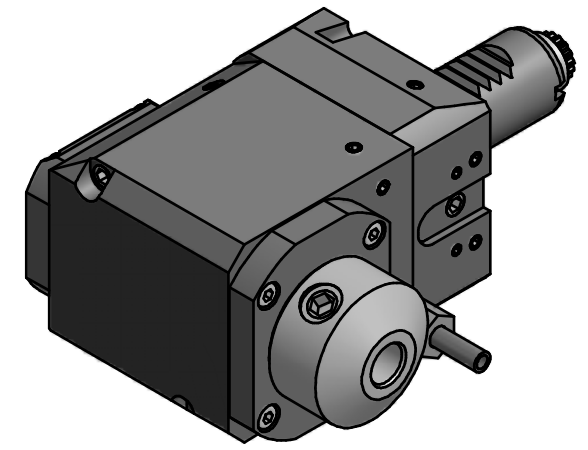
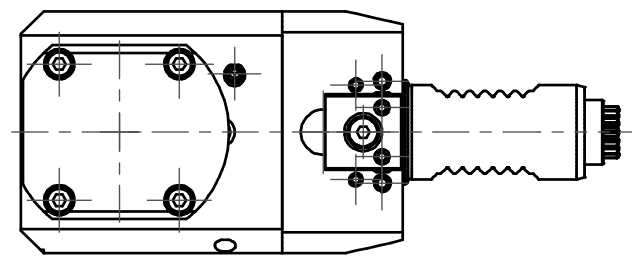

Copyright **EWS Tool Technologies**
Weitergabe und Vervielfaeltigung dieser Unterlage,
Verwertung und Mitteilung ihres Inhalts nicht
gestattet, soweit nicht ausdrecklich zugestanden.
Zuwiderhandlungen verpflichten zu Schadenersatz.

<p>Bemerkung - Note</p>	<p>Technische Daten - technical data</p> <p>M1 / M2 = 25 / 25 Nm n1 / n2 = 8000 / 8000 1/min i (N1:N2) = 1:1</p>	<p>Benennung - Title</p> <p>Radial Bohr und Fräskopf <i>Radial drilling and milling head</i></p>	<table border="1"> <tr> <td>name</td> <td>date</td> </tr> <tr> <td>Kratschmann</td> <td>13.11.2006</td> </tr> </table> <p>EWS EWS Weigete GmbH & Co. KG Maybachstr. 1 D-73066 Uhingen Tel. +49(0)7161/93040-100</p>	name	date	Kratschmann	13.11.2006	<p>Technische Aenderungen vorbehalten! Subject to technical modifications!</p> <p>Nr. 60.2512WNL5480RL</p> <p>MNR: 112439 IDENT: D-EWS-003069 A Blatt - page 1 (1)</p>
name	date							
Kratschmann	13.11.2006							

6 | 5 | 4 | 3 | 2 | 1