

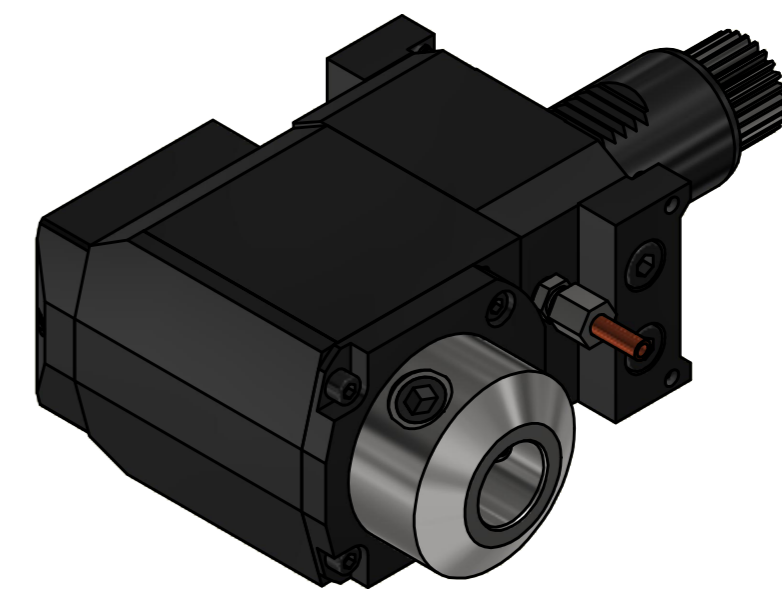

Ceramic Seal

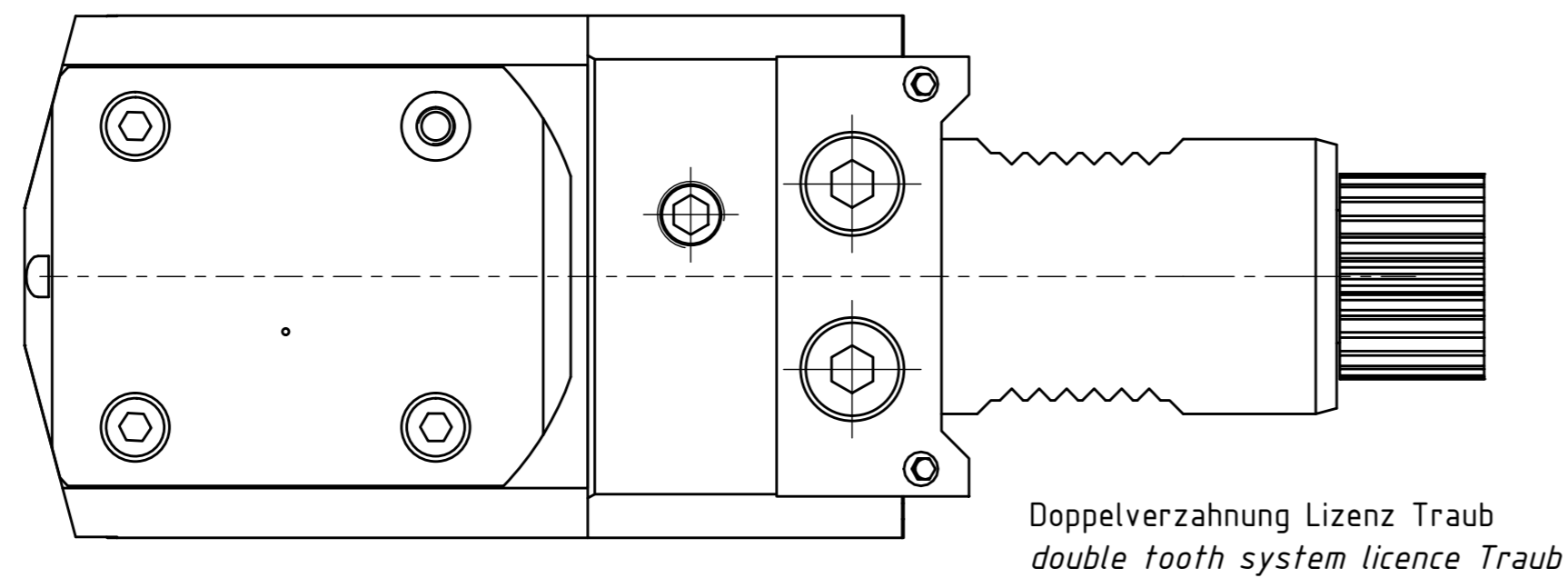

Tech Details

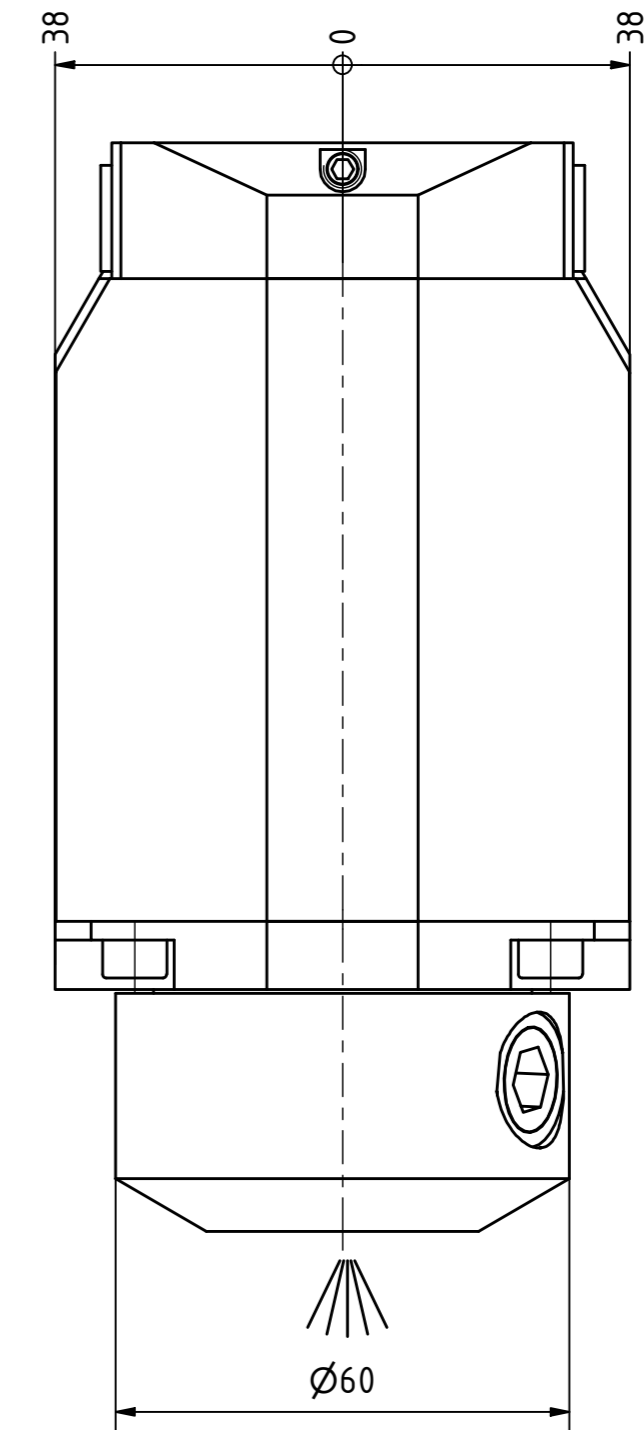
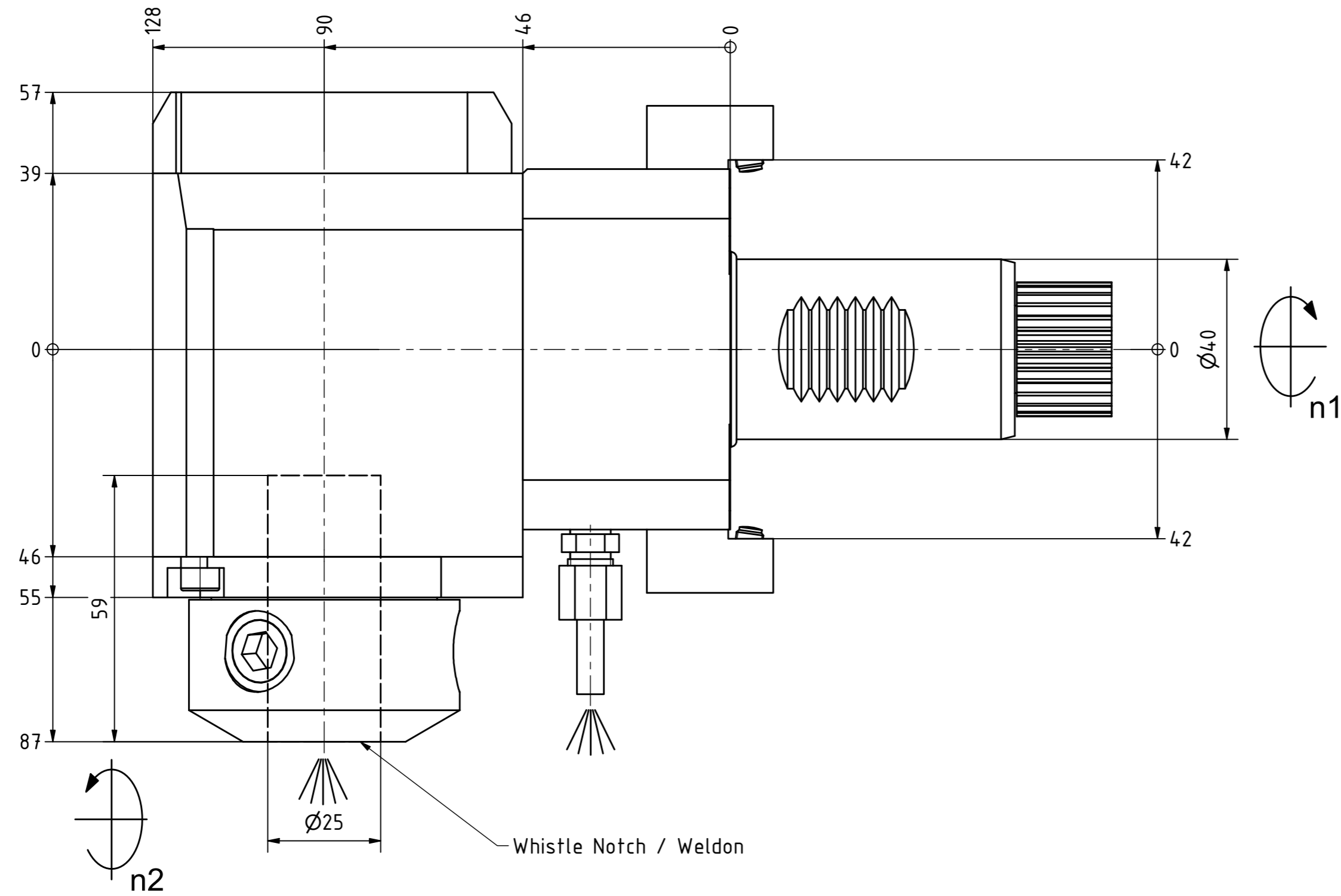

Copyright **EWS Tool Technologies**  
 Weitergabe und Vervielfältigung dieser Unterlage,  
 Verwertung und Mitteilung ihres Inhalts nicht  
 gestattet, soweit nicht ausdrücklich zugestanden.  
 Zuwiderhandlungen verpflichten zu Schadenersatz.

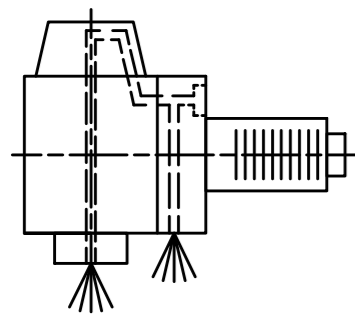

Innen- und Aussenkuehlung / Inside and outside coolant supply  
 Kuehlmittelfiltrierung-50µ / coolant filtration-50µ

Bemerkung - Note  
 Für Trockenlauf geeignet!  
 Use without coolant fluid allowed!  
 mit Kegelrollenlager  
 with taper roller bearing(s)

Technische Daten - technical data  
 Weight = 7.294 [kg]  
 Torque max. (M1/M2) = 40 / 80 [Nm]  
 Speed max. (n1/n2) = 6000 / 3000 [1/min]  
 Gear ratio (i)=n1:n2 = 2:1  
 Pressure (pmax) = 70 [bar]

Benennung - Title  
**Radial Bohr und Fräskopf**  
**Radial drilling and milling head**

<b>EWS</b> <small>Tool Technologies</small> <small>EWS Weigle GmbH &amp; Co. KG        Maybachstr. 1        D-73066 Ulm/ingen        www.ews-tool.de</small>	<small>Technische Änderungen vorbehalten!</small> <small>Subject to technical modifications!</small>	 <small>REV: -/B</small>
	<small>IDENT: D-EWS-061643</small>	
<small>Nr. - No.</small> <b>60.4025WNKRTNX65RLIKD12</b>	<small>MNR.</small> <b>143073</b>	

QR