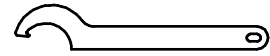
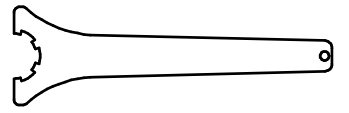

Schwenkbereich ±105°
Swivel area ±105°

Spannzange / collet ER25 DIN6499
Spannbereich / clamping range: 1,0 - 16,0

Gewindebohrzange / tapping collet
ET-1-25 M3-M10

 Hakenschlüssel
mit Nase
Hook wrench with
nose end
DIN1810 A 45x50

 Spannzangenschlüssel
Clamping wrench
225

Copyright **EWS Tool Technologies**
Weitergabe und Vervielfältigung dieser Unterlage,
Verwertung und Mitteilung ihres Inhalts nicht
gestattet, soweit nicht ausdrücklich zugestanden.
Zuwiderhandlungen verpflichten zu Schadenersatz.

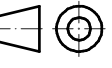
Bemerkung - Note	Technische Daten - technical data M1 / M2 = 20 / 20 Nm n1 / n2 = 6000 / 6000 1/min i (N1:N2) = 1:1	Benennung - Title Schwenkkopf <i>Swivel head</i>	<table border="1"> <tr> <th>name</th> <th>date</th> </tr> <tr> <td>drawing</td> <td>26.02.2007</td> </tr> </table>	name	date	drawing	26.02.2007	Technische Aenderungen vorbehalten! Subject to technical modifications! Nr. 63.4025TOEM File: 63.4025TOEM_OUT.idw	 DIN A3 Blatt - page 1 (1)
name	date								
drawing	26.02.2007								