

Spannzange / collet ER25 DIN6499  
 Spannbereich / clamping range: 1,0 - 16,0

Gewindebohrzange / tapping collet  
 ET-1-25 M3-M10

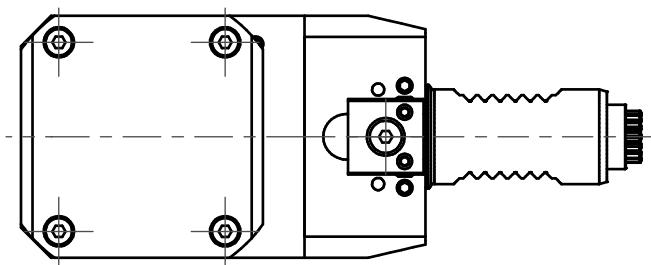

Doppelverzahnung Lizenz Traub  
 double tooth system licence Traub

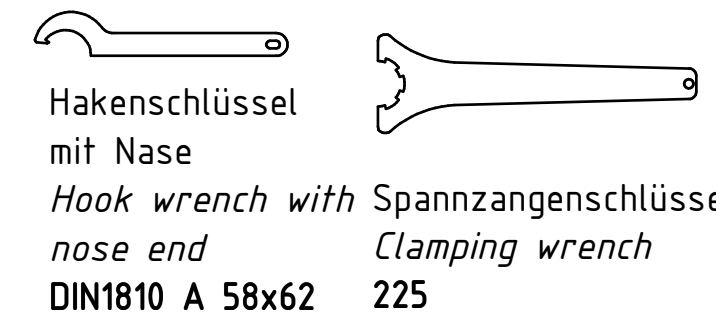
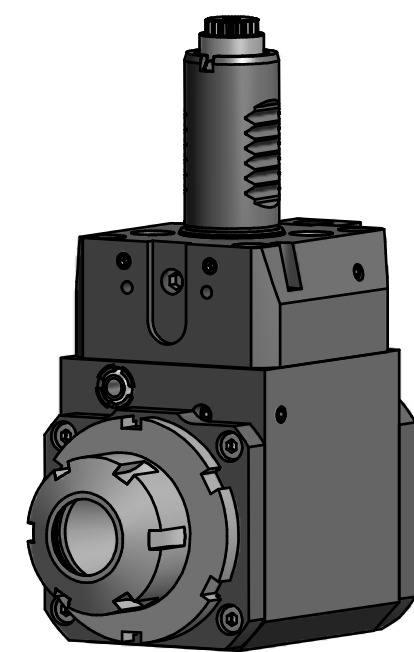

DIN1810 A 58x62 225

Copyright **EWS Tool Technologies**  
 Weitergabe und Vervielfaeltigung dieser Unterlage,  
 Verwertung und Mitteilung ihres Inhalts nicht  
 gestattet, soweit nicht ausdrecklich zugestanden.  
 Zuwiderhandlungen verpflichten zu Schadenersatz.

Bemerkung - Note mit Kegelrollenlager with taper roller bearing(s)	Technische Daten - technical data M1 / M2= 20 /60 Nm n1 / n2 = 6000 /2000 1/min i (N1:N2) = 3:1	Benennung - Title <b>Radial Bohr und Fräskopf</b> <b>Radial drilling and milling head</b>	<table border="1"> <tr> <td>name</td> <td>date</td> </tr> <tr> <td>Seeh</td> <td>14.05.2008</td> </tr> </table>	name	date	Seeh	14.05.2008	Technische Aenderungen vorbehalten! Subject to technical modifications! Nr. <b>60.2525KRL5480RLI3</b>	DIN A3 Blatt - page 1 (1)
name	date								
Seeh	14.05.2008								