

Spannzange / collet ER20 DIN6499  
Spannbereich / clamping range: 1,0 - 13,0

Gewindebohrzange / tapping collet  
ET-1-20 M2-M6

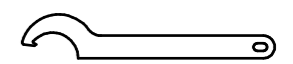
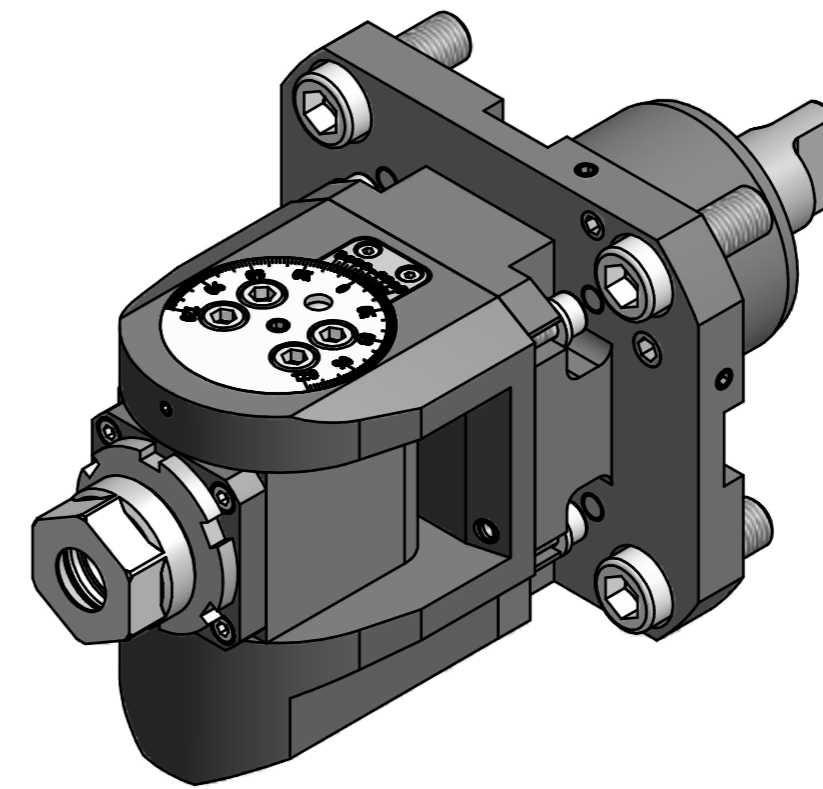
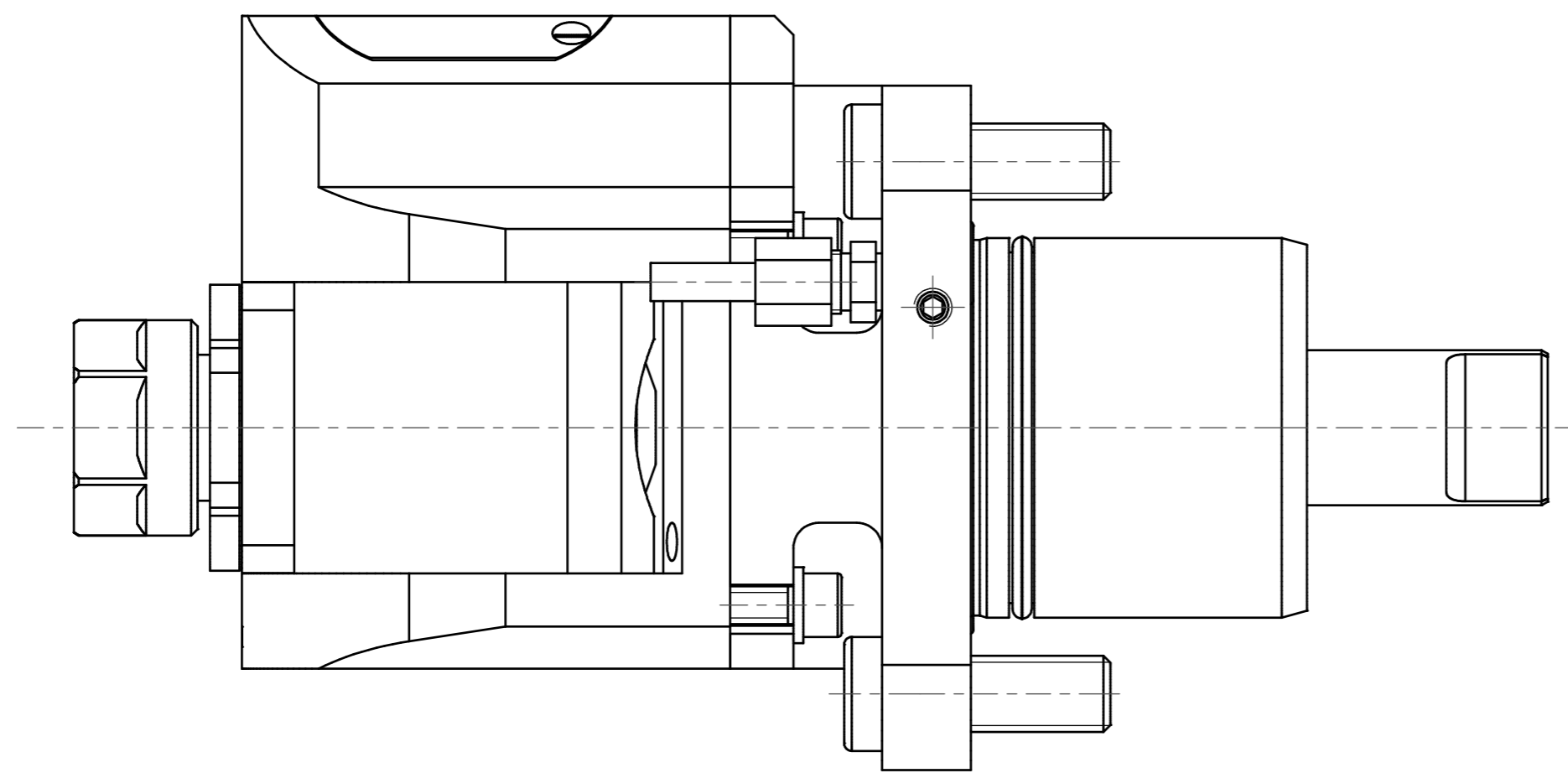

Hakenschlüssel  
mit Nase  
Hook wrench with  
nose end  
DIN1810 A 45x50

Copyright **EWS Tool Technologies**  
Weitergabe und Vervielfältigung dieser Unterlage,  
Verwertung und Mitteilung ihres Inhalts nicht  
gestattet, soweit nicht ausdrücklich zugestanden.  
Zuwendungen verpflichten zu Schadenersatz.

Bemerkung - Note	Technische Daten - Technical data		Benennung - Title	name M.Auracher date 27.07.2015 Technische Änderungen vorbehalten! Subject to technical modifications! Nr. <b>63.6020NL</b> <small>EWS EWS Weigete GmbH &amp; Co. KG Maybachstr. 1 D-72096 Ulm/lingen Tel. +49(0)7161/93040-100</small>	 DIN A2
	M <sub>1</sub> / M <sub>2</sub> = 20 / 20 Nm n <sub>1</sub> / n <sub>2</sub> = 6000 / 6000 1/min i (N <sub>1</sub> :N <sub>2</sub> ) = 1:1				