

Doppelverzahnung Lizenz Traub
double tooth system licence Traub

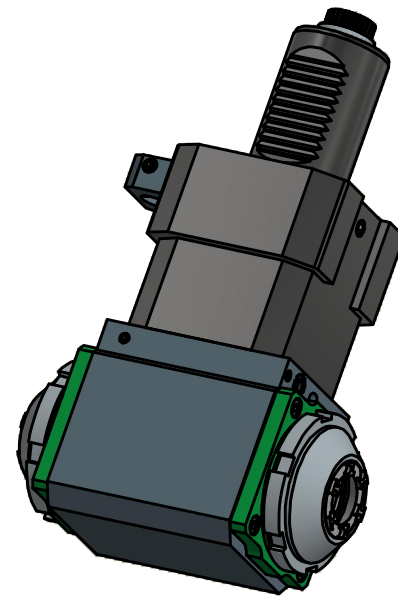
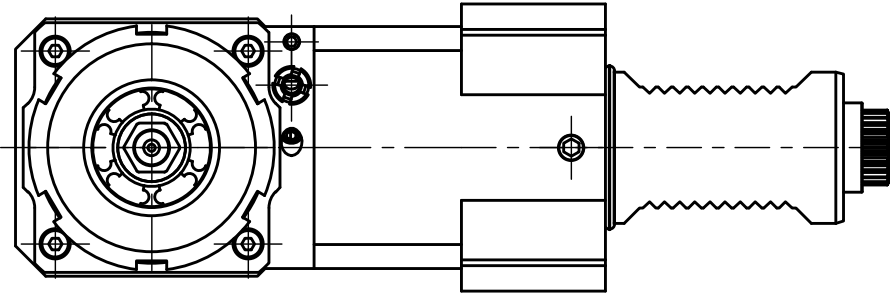

Spannzange / collet ER25 DIN6499
Spannbereich / clamping range: 1,0 - 16,0

Spannzangenschlüssel für innenliegende Mutter
Clamping wrench for internal collet
225AX

Hakenschlüssel mit Nase
Hook wrench with nose end
DIN1810 A 68x75



Copyright **EWS Tool Technologies**
Weitergabe und Vervielfältigung dieser Unterlage, Verwertung und Mitteilung ihres Inhalts nicht gestattet, soweit nicht ausdrücklich zugestanden. Zuwiderhandlungen verpflichten zu Schadenersatz.

Bemerkung - Note 	Technische Daten - technical data Weight = 7.012 [kg] Torque max. (M1/M2) = 25 / 25 25 [Nm] Speed max. (n1/n2) = 6000 / 6000 [1/min] Gear ratio (i)=n1:n2 = 1:1	Benennung - Title Radial Bohr und Fräskopf Radial drilling and milling head	 EWS <small>EWS Weigele GmbH & Co. KG Maybachstr. 1 D-73066 Uthingen www.ews-tools.de</small>	Technische Änderungen vorbehalten! Subject to technical modifications! IDENT: D-EWS-060277	 REV: -/- MNR. 142221	
			Nr. - No. 60.4025LDCTXRLIM-BG30			