

Doppelverzahnung Lizenz Traub
 double tooth system licence Traub

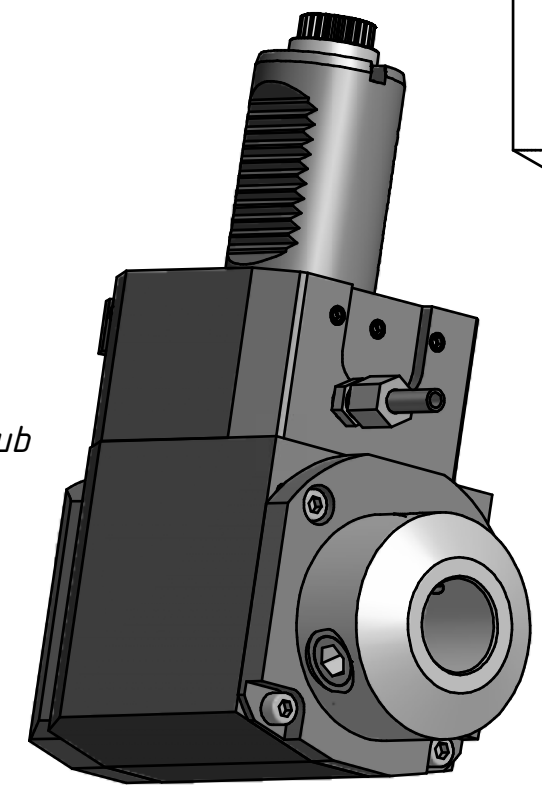

Copyright **EWS Tool Technologies**
 Weitergabe und Vervielfaeltigung dieser Unterlage,
 Verwertung und Mitteilung ihres Inhalts nicht
 gestattet, soweit nicht ausdrecklich zugestanden.
 Zuwiderhandlungen verpflichten zu Schadenersatz.

Bemerkung - Note mit Kegelrollenlager <i>with taper roller bearing(s)</i>	Technische Daten - technical data M1 / M2 = 40 / 80 Nm n1 / n2 = 6000 / 3000 1/min i (N1:N2) = 2:1	Benennung - Title Radial Bohr und Fräskopf <i>Radial drilling and milling head</i>	<table border="1"> <tr> <td>name</td> <td>date</td> </tr> <tr> <td>Theiss</td> <td>03.06.2008</td> </tr> </table>	name	date	Theiss	03.06.2008	Technische Aenderungen vorbehalten! <i>Subject to technical modifications!</i> Nr. 60.4025WNKRCTXRLI2X90 File: D-EWS-061677.idw Blatt - page 1 (1)
name	date							
Theiss	03.06.2008							

