

Spannzange / collet ER32 DIN6499  
 Spannungsbereich / clamping range: 2,0 - 20,0

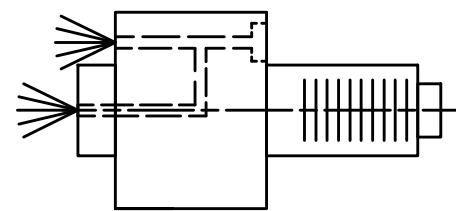

Innen- und Aussenkuehlung / Inside and outside coolant supply  
 Kein Trockenlauf / No dry run  
 Kuehlmittelfiltrierung <math>< 50\mu</math> / coolant filtration <math>< 50\mu</math>

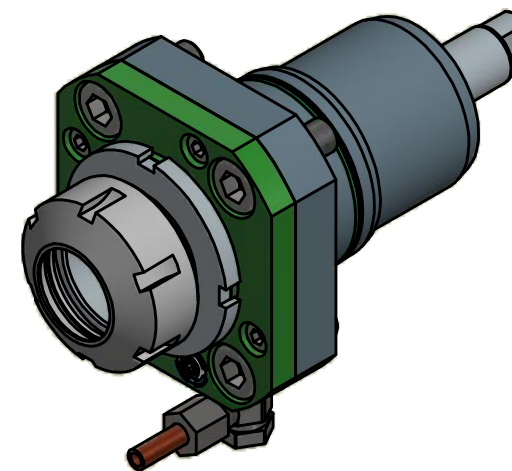

Spannzangenschlüssel  
 Clamping wrench  
 232

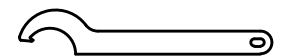

Hakenschlüssel  
 mit Nase  
 Hook wrench with  
 nose end  
 DIN1810 A 58x62

Copyright **EWS Tool Technologies**  
 Weitergabe und Vervielfaeltigung dieser Unterlage,  
 Verwertung und Mitteilung ihres Inhalts nicht  
 gestattet, soweit nicht ausdruercklich zugestanden.  
 Zuwiderhandlungen verpflichten zu Schadenersatz.

Bemerkung - Note  
 Nicht ohne Kuehlmittel betreiben!  
 Not for use without coolant-fluid!

Technische Daten - technical data  
 Weight = 2.310 [kg]  
 Torque max. (M1/M2) = 25 / 25 [Nm]  
 Speed max. (n1/n2) = 6000 / 6000 [1/min]  
 Gear ratio (i)=n1:n2 = 1:1  
 Pressure (pmax) = 25 [bar]

Benennung - Title  
 Axial Bohr und Fräskopf  
 Axial drilling and milling head

**EWS**  
 Tool Technologies  
 EWS Weigle GmbH & Co. KG  
 Maybachstr. 1  
 D-73066 Uehingen  
 www.ews-tools.de

Technische Aenderungen vorbehalten!  
 Subject to technical modifications!

IDENT: DEWS061917

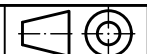

REV: -/B

Nr. - No.

40.5532TW10IK

MNR.

141994

QR