

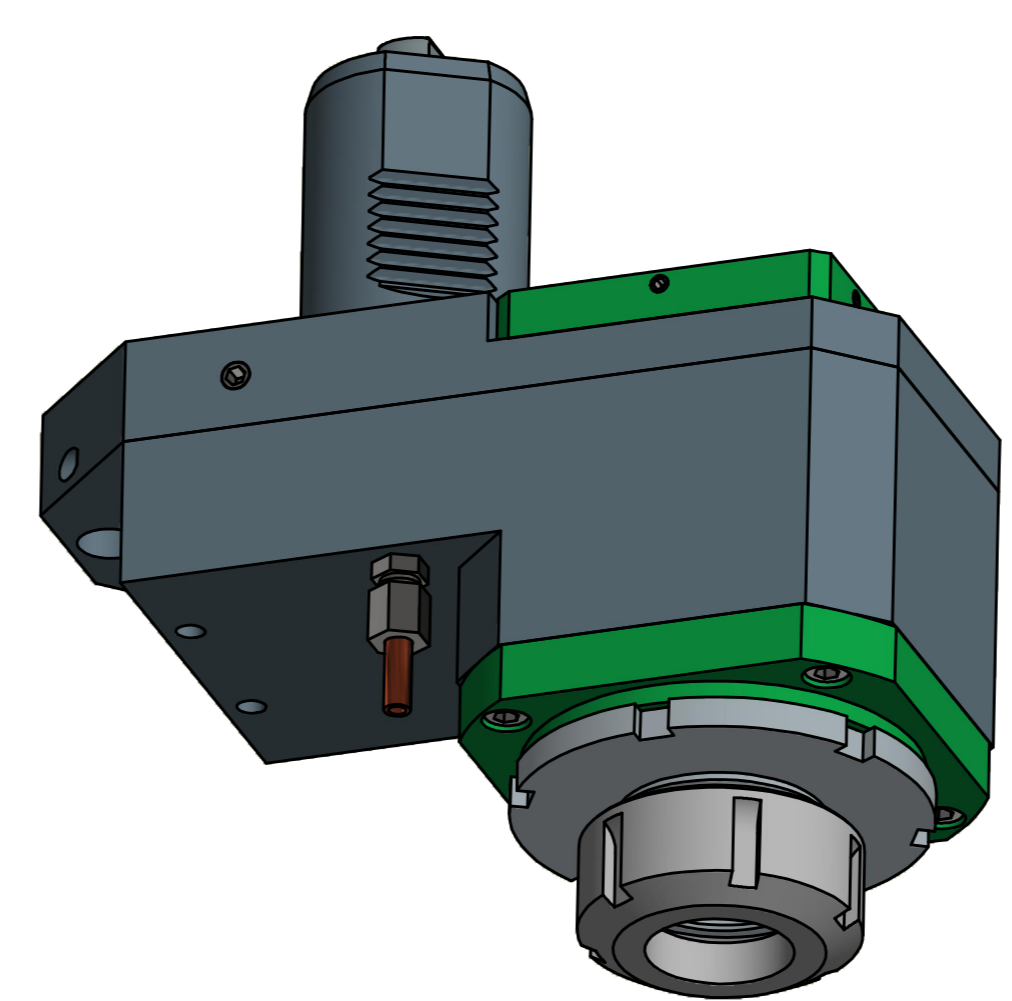

Spannzange / collet ER40 DIN6499
 Spannbereich / clamping range: 3,0 - 26,0

Gewindebohrzange / tapping collet
 ET-1-40 M6-M16

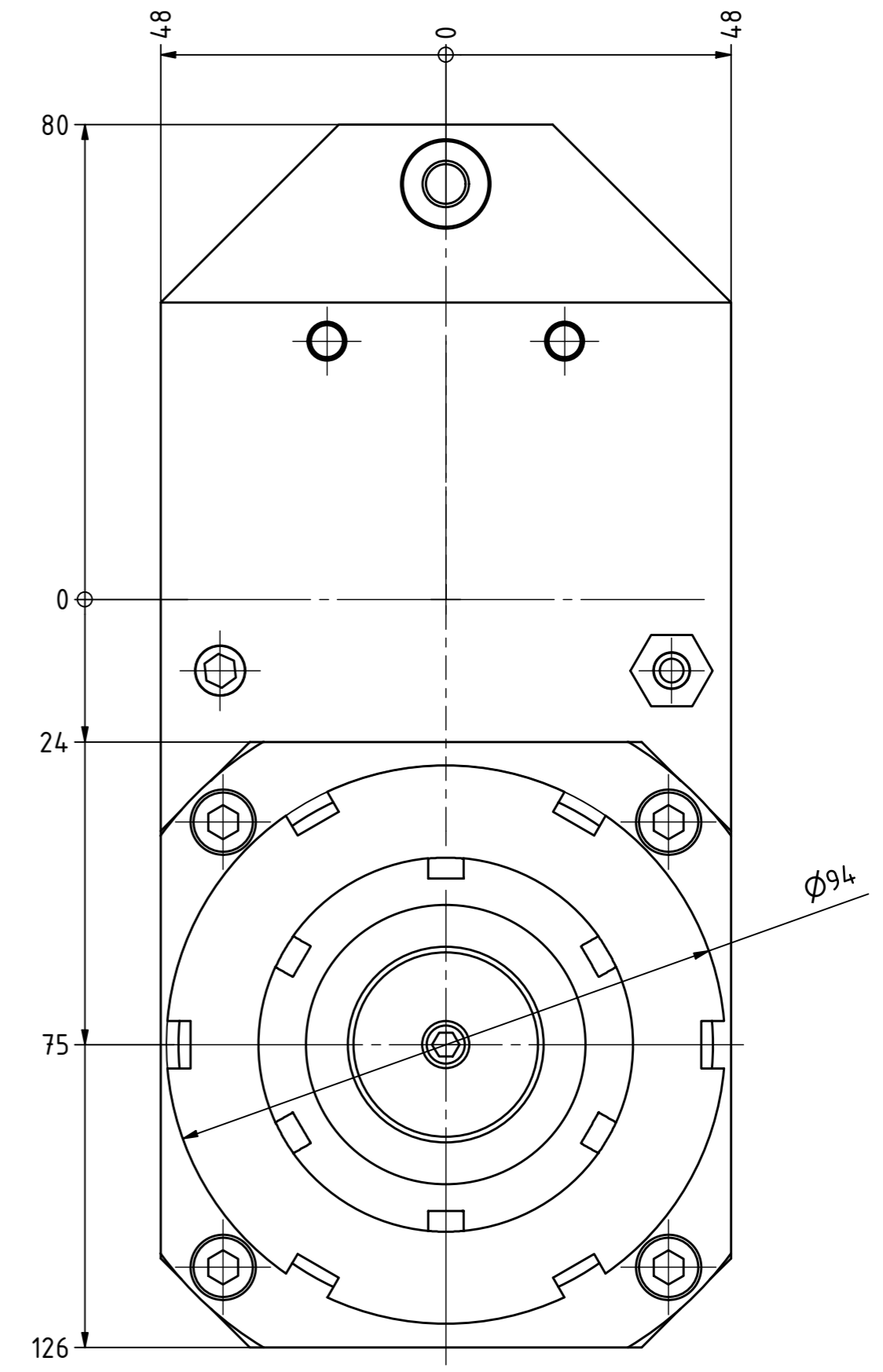
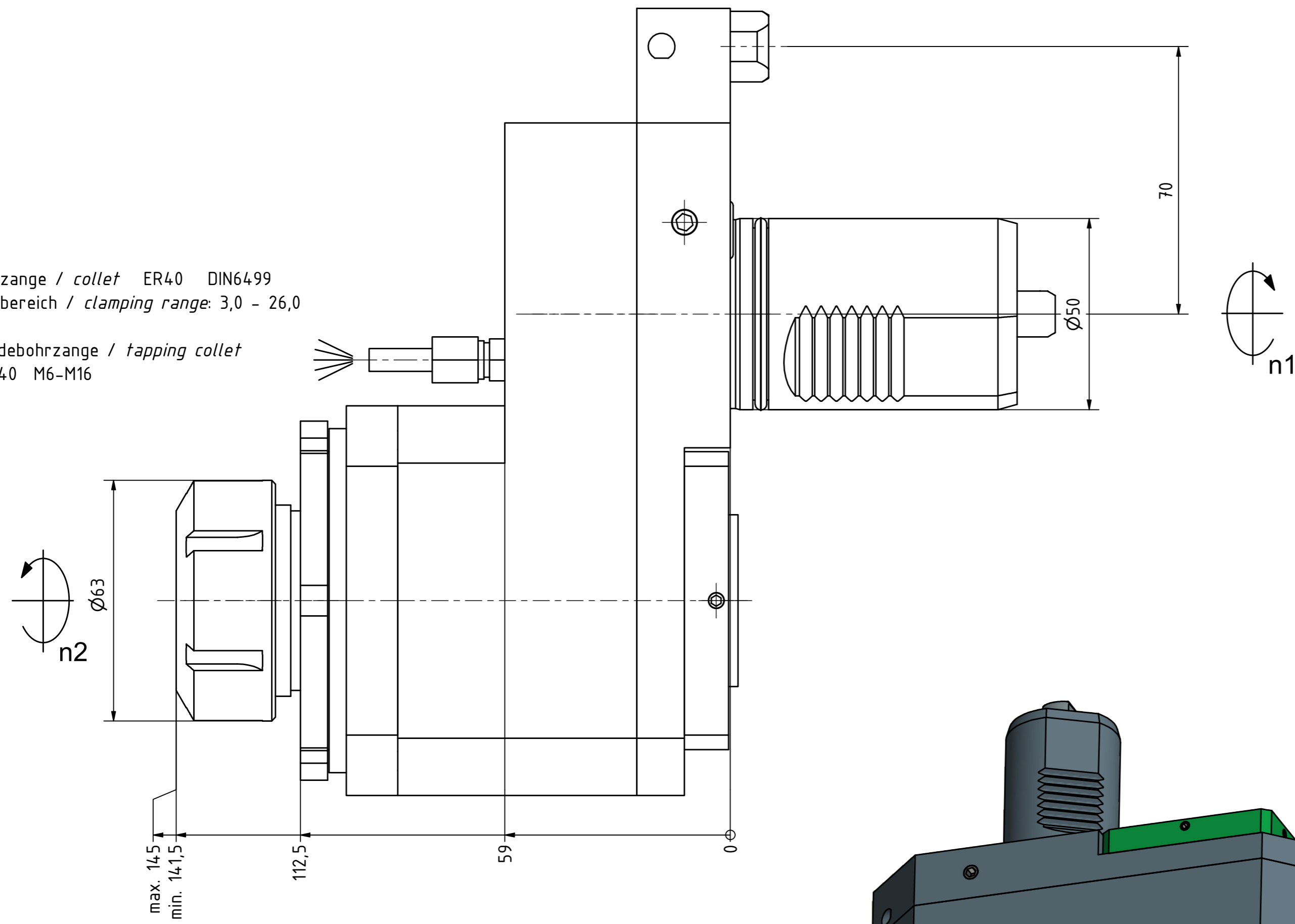

 Spannzangenschlüssel
 Clamping wrench
 240

 Hakenschlüssel
 mit Nase
 Hook wrench with
 nose end
 DIN1810 A 95x100

Copyright **EWS Tool Technologies**
 Weitergabe und Vervielfältigung dieser Unterlage,
 Verwertung und Mitteilung ihres Inhalts nicht
 gestattet, soweit nicht ausdrücklich zugestanden.
 Zuwiderhandlungen verpflichten zu Schadenersatz.

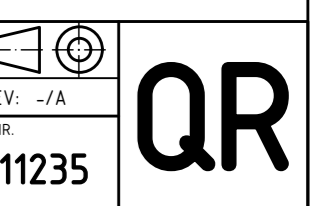
Bemerkung - Note	Technische Daten - technical data Weight = 11,416 [kg] Torque max. (M1/M2) = 100 / 100 [Nm] Speed max. (n1/n2) = 6000 / 6000 [1/min] Gear ratio (i)=n1:n2 = 1:1	Benennung - Title Axial Bohr u. Fräskopf achsversetzt Ax. drill. and mill. head offset	 EWS Weigle GmbH & Co. KG Maybachstr. 1 D-73066 Ulm/ingen www.ews-tools.de Nr. - No. 50.5040SQT28R	Technische Änderungen vorbehalten! Subject to technical modifications! IDENT: DEWS123167 REV: -/A MNR. 111235	
------------------	---	--	---	---	---