

Fräserwelle austauschbar
Spindle removable

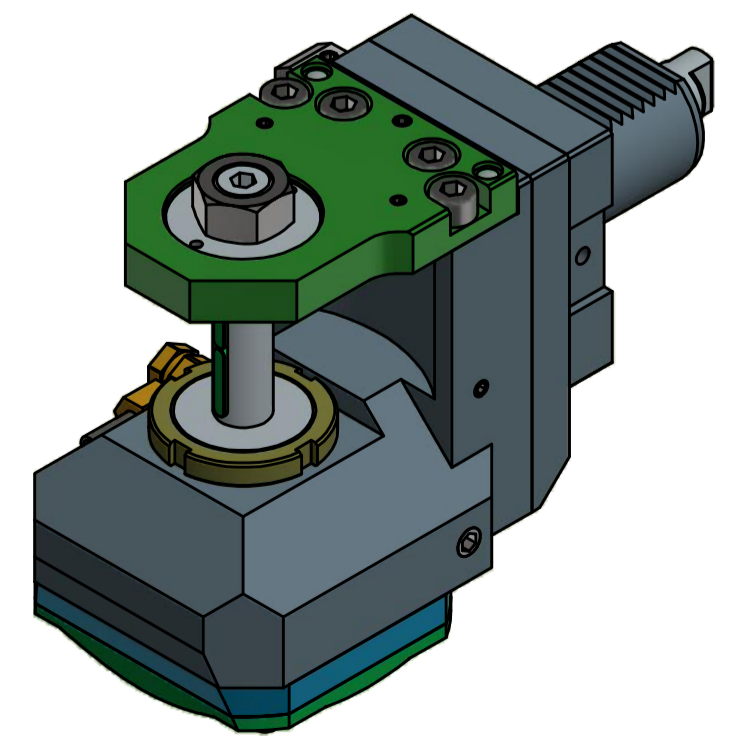
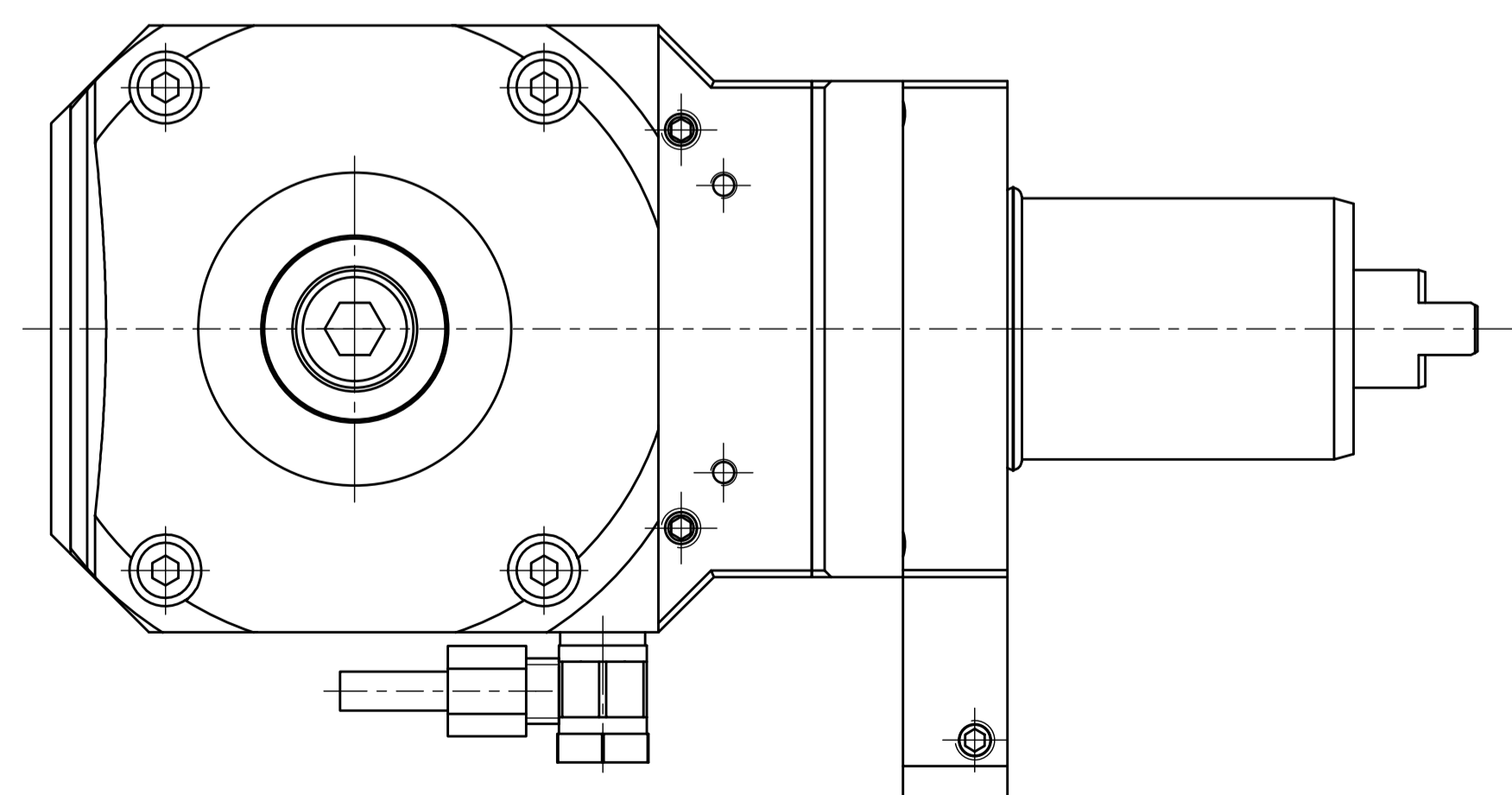

Copyright EWS Tool Technologies
Weitergabe und Vervielfältigung dieser Unterlage,
Verwertung und Mitteilung ihres Inhalts nicht
gestattet, soweit nicht ausdrücklich zugestanden.
Zu widerhandlungen verpflichten zu Schadenersatz.

Bemerkung - Note Technische Daten - Technical data Weight = 7.601 [kg] Torque max. (M1/M2) = 50 / 150 [Nm] Speed max. (n1/n2) = 6000 / 2000 [1/min] Gear ratio $i = n1:n2 = 3:1$	Scheibenfräserkopf Radial saw milling head	EWS Werkzeug GmbH & Co. KG Hauptstr. 1 64700 Kelkheim www.ews-tool.de Technische Änderungen vorbehalten! Subject to technical modifications! IDENT: D-EWS-000862 Nr. - No. 64.4.016180913	QR 110633
---	---	---	--------------