

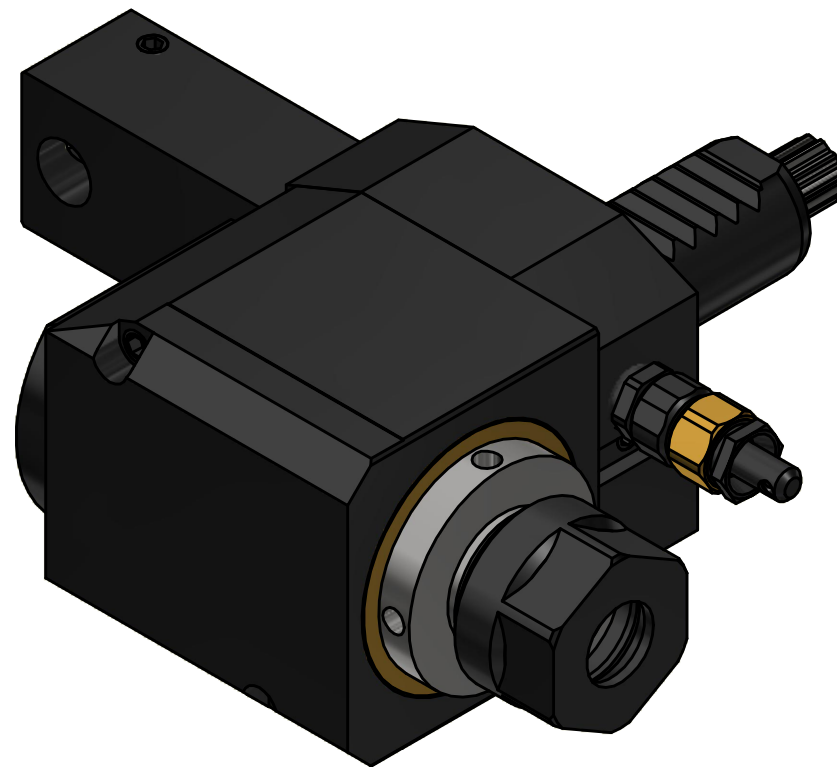



Hakenschlüssel
mit Zapfen
Hook wrench
with fixed pin
DIN1810 B 34x36



Spannzange / Collet ER16 DIN6499
Spannbereich / Clamping range: 1,0 - 10,0

Gewindebohrzange / Tapping Collet
ET-1-16 M1-M6

Copyright **EWS Tool Technologies**
Weitergabe und Vervielfältigung dieser Unterlage,
Verwertung und Mitteilung ihres Inhalts nicht
gestattet, soweit nicht ausdrücklich zugestanden.
Zuwerhandlungen verpflichten zu Schadenersatz.

| | | | | | | |
|------------------|--|---|--|---|--|---|
| Bemerkung - Note | Technische Daten - technical data Weight = 1.652 [kg] Torque max. (M1/M2) = 10 / 10 [Nm] Speed max. (n1/n2) = 8000 / 8000 [1/min] Gear ratio (i)=n1:n2 = 1:1 | Benennung - Title Radial Bohr und Fräskopf <i>Radial drilling and milling head</i> |  EWS <small>EWS Weigle GmbH & Co. KG Maybachstr. 1 D-73066 Utingen www.ews-tools.de</small> | Technische Änderungen vorbehalten! <i>Subject to technical modifications!</i> IDENT: DEWS155351 |  REV: -/C MNR. 111225 |  |
| | | | Nr. - No. 60.20165480R | | | |