

Spannzange / collet ER40 DIN6499  
Spannbereich / clamping range: 3,0 - 26,0

Gewindebohrzange / tapping collet  
ET-1-40 M6-M16

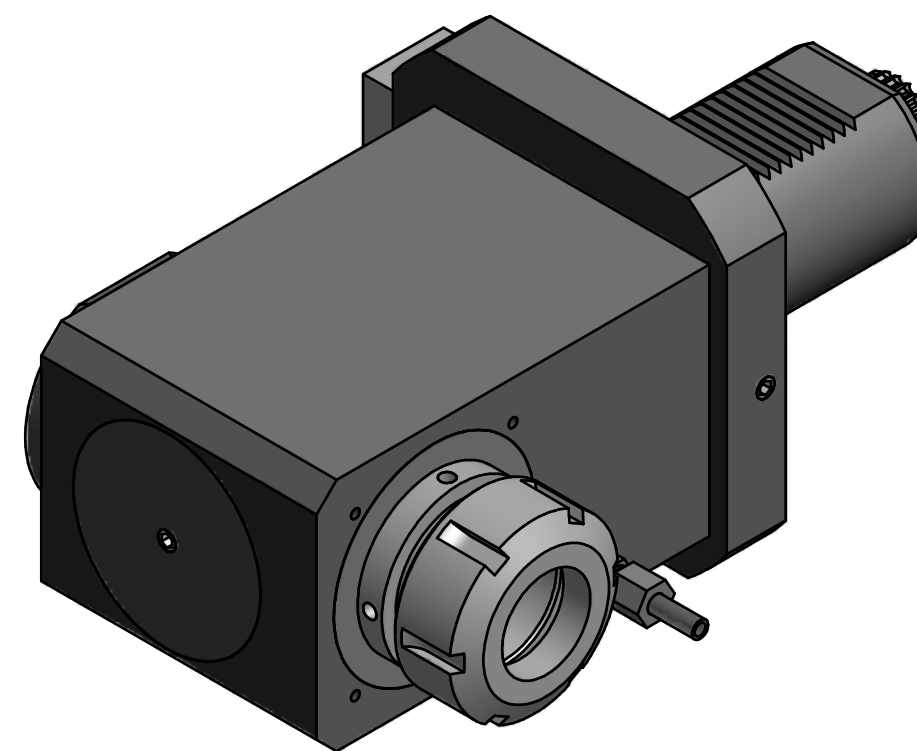
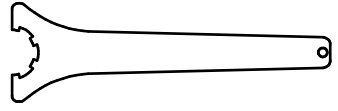

  
Hakenschlüssel  
mit Zapfen  
Hook wrench  
with fixed pin  
DIN1810 B 58x62

  
Spannzangenschlüssel  
Clamping wrench  
240

Copyright **EWS Tool Technologies**  
Weitergabe und Vervielfältigung dieser Unterlage,  
Verwertung und Mitteilung ihres Inhalts nicht  
gestattet, soweit nicht ausdrücklich zugestanden.  
Zuwerhandlungen verpflichten zu Schadenersatz.

Bemerkung - Note	Technische Daten - Technical data		Benennung - Title	name date Technische Änderungen vorbehalten! Subject to technical modifications!	 Nr. <b>60.604.0DOSRGL0T09-BG50</b> DIN A2
	M <sub>1</sub> / M <sub>2</sub> = 100 / 100 Nm n <sub>1</sub> / n <sub>2</sub> = 3000 / 3000 1/min i (N <sub>1</sub> :N <sub>2</sub> ) = 1:1	<b>Radial Bohr und Fräskopf</b> <b>Radial drilling and milling head</b>			