

Spannzange / collet ER25 DIN6499
 Spannbereich / clamping range: 1,0 - 16,0

Gewindebohrzange / tapping collet
 ET-1-25 M3-M12

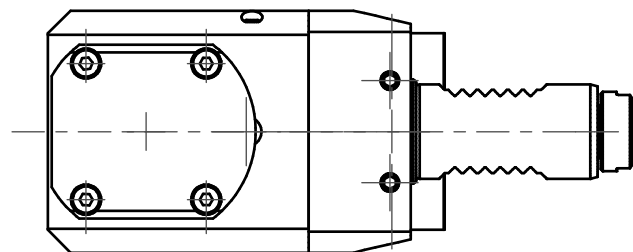

Doppelverzahnung Lizenz Traub
 double tooth system licence Traub

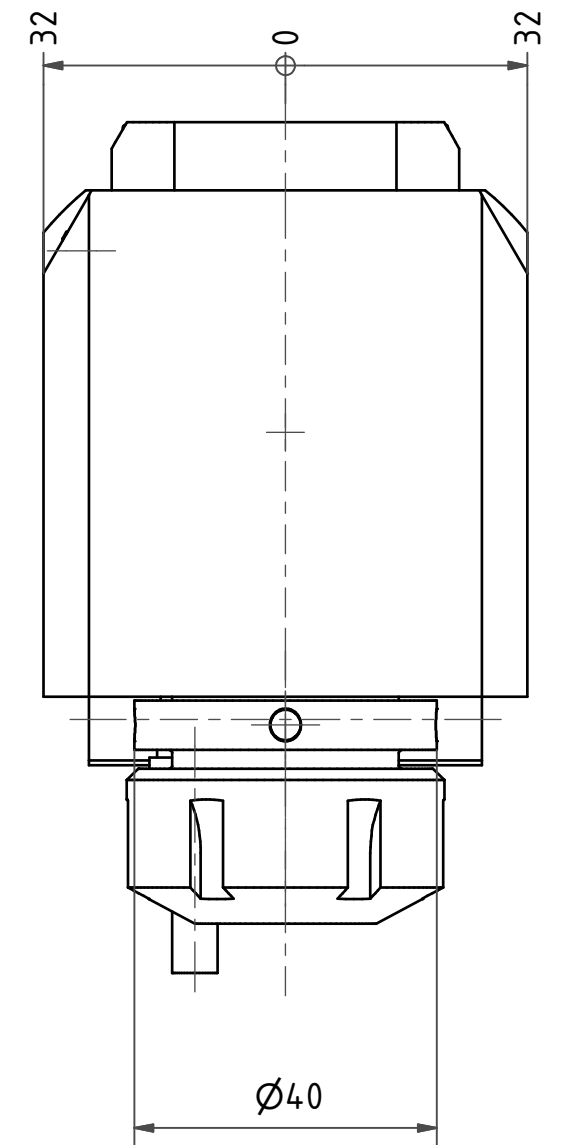
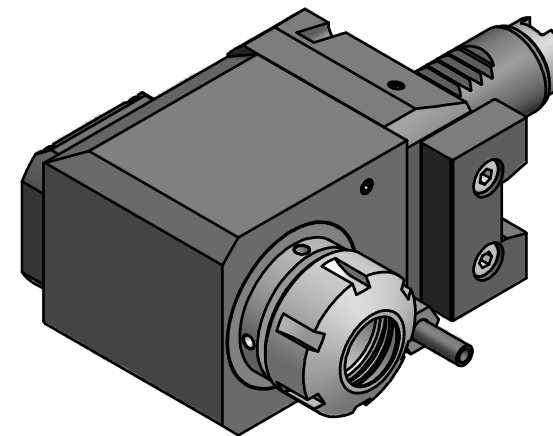

Hakenschlüssel
 mit Zapfen
 Hook wrench
 with fixed pin

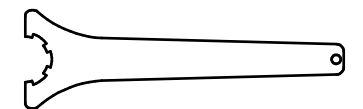

Spannzangenschlüssel
 Clamping wrench

DIN1810 B 40x42 225

Copyright **EWS Tool Technologies**
 Weitergabe und Vervielfaeltigung dieser Unterlage,
 Verwertung und Mitteilung ihres Inhalts nicht
 gestattet, soweit nicht ausdruuecklich zugestanden.
 Zuwiderhandlungen verpflichten zu Schadenersatz.

Bemerkung - Note

Technische Daten - technical data

Weight = 3.177 [kg]
 Torque max. (M1/M2) = 20 / 40 [Nm]
 Speed max. (n1/n2) = 6000 / 3000 [1/min]
 Gear ratio (i)=n1:n2 = 2:1

Benennung - Title

Radial Bohr und Fräskopf
Radial drilling and milling head

EWS
 Tool Technologies
EWS Weigle GmbH & Co. KG
 Maybachstr. 1
 D-73066 Uhingen
 www.ews-tools.de

Technische Aenderungen vorbehalten!
 Subject to technical modifications!

IDENT: D-EWS-203364

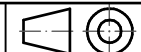

REV: -/-

Nr. - No.

60.2525G200RLI2V

MNR.

110365

QR