

Spannzange / collet ER25 DIN6499
 Spannbereich / clamping range: 1,0 - 16,0

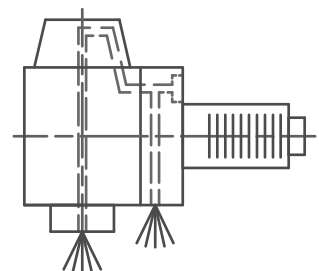
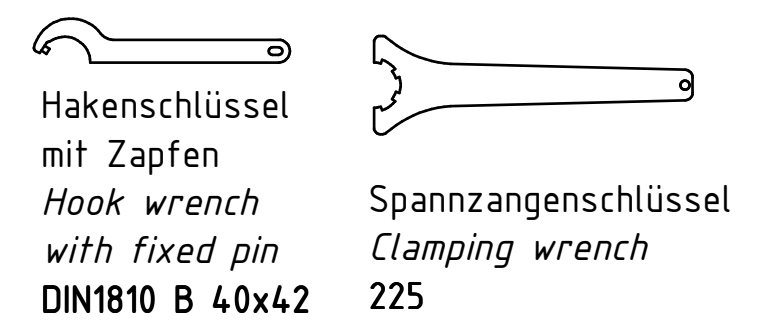
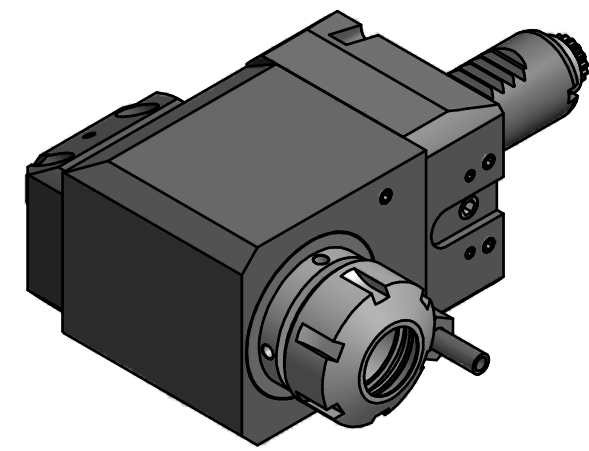

Innen- und Aussenkuehlung / Inside and outside coolant supply
 Kein Trockenlauf / No dry run
 Kuehlmittelfiltrierung=50µ / coolant filtration=50µ

Copyright **EWS Tool Technologies**
 Weitergabe und Vervielfaeltigung dieser Unterlage,
 Verwertung und Mitteilung ihres Inhalts nicht
 gestattet, soweit nicht ausdrecklich zugestanden.
 Zuwiderhandlungen verpflichten zu Schadenersatz.

Bemerkung - Note Nicht ohne Kuehlmittel betreiben! Not for use without coolant-fluid!	Technische Daten - technical data M1 / M2 = 25 / 25 Nm n1 / n2 = 8000 / 8000 1/min i (N1:N2) = 1:1 pmax = 70 bar	Benennung - Title Radial Bohr und Fräskopf <i>Radial drilling and milling head</i>	name	date	Technische Aenderungen vorbehalten! Subject to technical modifications!	Nr. 60.2525L5480RIK	DIN A3
			drawing	Theiss			
			EWS Weigele GmbH & Co. KG Maybachstr. 1 D-73066 Uhingen Tel. +49(0)7161/93040-100		MNR: 110598 IDENT: D-EWS-14.7966 A		Blatt - page 1 (1)