

Doppelverzahnung Lizenz Traub
double tooth system licence Traub 225AX

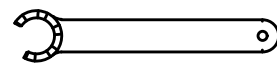

Spannzangenschlüssel für
innenliegende Mutter
Clamping wrench for
internal collet

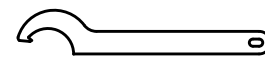

Hakenschlüssel
mit Nase
Hook wrench with
nose end
DIN1810 A 52x55

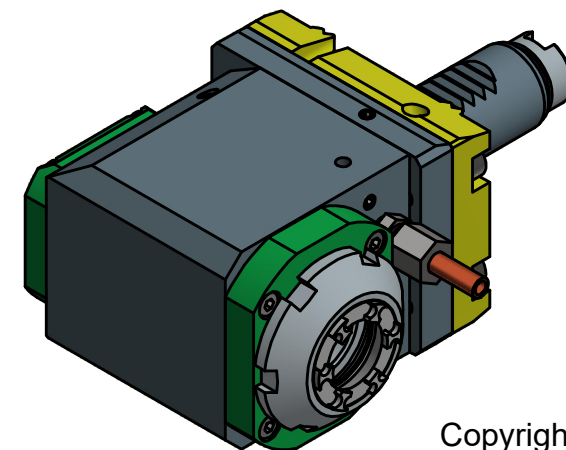

Copyright **EWS Tool Technologies**
Weitergabe und Vervielfältigung dieser Unterlage,
Verwertung und Mitteilung ihres Inhalts nicht
gestattet, soweit nicht ausdrücklich zugestanden.
Zu widerhandlungen verpflichten zu Schadenersatz.

Bemerkung - Note

Technische Daten - technical data

Weight = 3.300 [kg]
Torque max. (M1/M2) = 25 / 25 [Nm]
Speed max. (n1/n2) = 8000 / 8000 [1/min]
Gear ratio (i)=n1:n2 = 1:1

Benennung - Title

Radial Bohr und Fräskopf
Radial drilling and milling head

EWS
Tool Technologies

Nr. - No.

60.2525G200RLWIM

EWS Weigele GmbH & Co. KG
Maybachstr. 1
D-73066 UHINGEN
www.ews-tools.de

Technische Änderungen vorbehalten!
Subject to technical modifications!

IDENT: D-EWS-059786

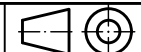

REV: -/A

MNR.

141842

QR