

min. 28  
max. 31,5  
38

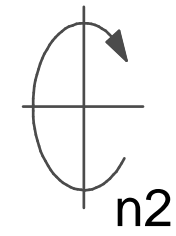

Spannzange / collet ER25 DIN6499  
Spannbereich / clamping range: 1,0 - 16,0

Gewindebohrzange / tapping collet  
ET-1-25 M3-M10

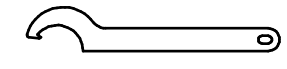
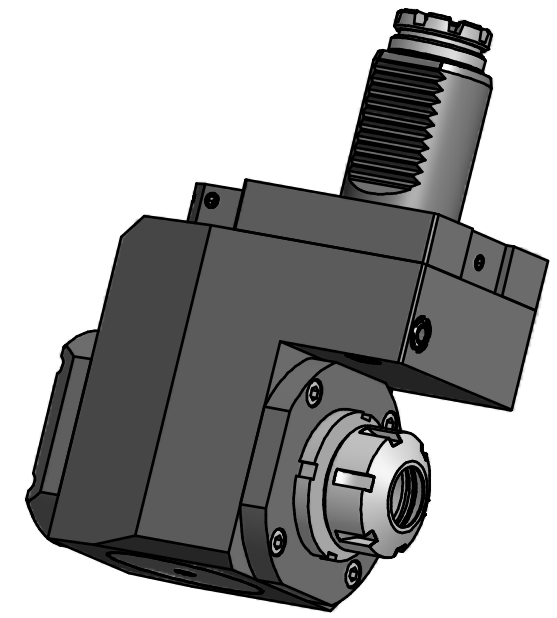

Hakenschlüssel  
mit Nase  
Hook wrench with  
nose end  
DIN1810 A 45x50

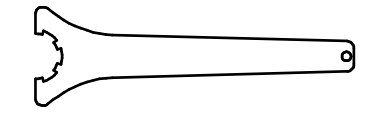

Spannzangenschlüssel  
Clamping wrench  
225

Copyright **EWS Tool Technologies**  
Weitergabe und Vervielfaeltigung dieser Unterlage,  
Verwertung und Mitteilung ihres Inhalts nicht  
gestattet, soweit nicht ausdrecklich zugestanden.  
Zuwoiderhandlungen verpflichten zu Schadenersatz.

Bemerkung - Note	Technische Daten - technical data M1 / M2 = 50 / 50 Nm n1 / n2 = 6000 / 6000 1/min i (N1:N2) = 1:1	Benennung - Title <b>Radial Bohr und Fräskopf. zurückges</b> <b>Radial drill. and mill. head offset</b>	<table border="1"> <tr> <th>name</th> <th>date</th> </tr> <tr> <td>Kratschmann</td> <td>27.06.2007</td> </tr> </table>	name	date	Kratschmann	27.06.2007	Technische Aenderungen vorbehalten! Subject to technical modifications! Nr. <b>80.4025TOEMR</b> MNR: 110732 IDENT: D-EWS-048001 - Blatt - page 1 (1)
name	date							
Kratschmann	27.06.2007							

