

Doppelverzahnung Lizenz Traub  
double tooth system licence Traub

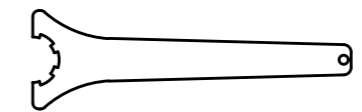

Spannzangenschlüssel  
Clamping wrench  
232

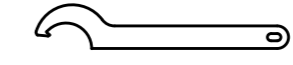

Hakenschlüssel  
mit Nase  
Hook wrench with  
nose end  
DIN1810 A 58x62

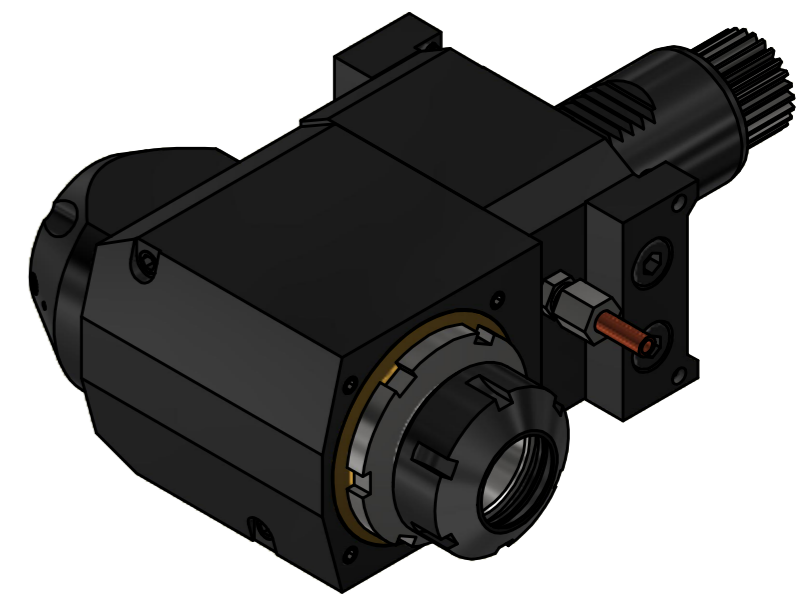

Copyright **EWS Tool Technologies**  
Weitergabe und Vervielfältigung dieser Unterlage,  
Verwertung und Mitteilung ihres Inhalts nicht  
gestattet, soweit nicht ausdrücklich zugestanden.  
Zuwiderhandlungen verpflichten zu Schadenersatz.

Spannzange / collet ER32 DIN6499  
Spannbereich / clamping range: 2,0 - 20,0

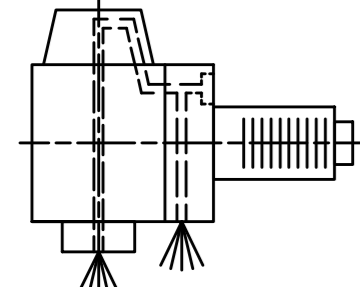

Innen- und Aussenkuehlung / Inside and outside coolant supply  
Kein Trockenlauf / No dry run  
Kuehlmittelfiltrierung=50µ / coolant filtration=50µ

<p>Bemerkung - Note Nicht ohne Kuehlmittel betreiben! Not for use without coolant-fluid!</p>	<p>Technische Daten - technical data Weight = 6.872 [kg] Torque max. (M1/M2) = 50 / 25 [Nm] Speed max. (n1/n2) = 5000 / 10000 [1/min] Gear ratio (i)=n1:n2 = 1:2 Pressure (pmax) = 70 [bar]</p>	<p>Benennung - Title <b>Radial Bohr und Fräskopf</b> <b>Radial drilling and milling head</b></p>	<p><b>EWS</b> Tool Technologies EWS Weigle GmbH &amp; Co. KG Maybachstr. 1 D-73066 Uhingen www.ews-tool.de</p>	<p>Technische Aenderungen vorbehalten! Subject to technical modifications! IDENT: DEWS233852 REV: -/A</p>	<p>Nr. - No. <b>60.4032TNX65RLIK1</b> MNR. <b>141541</b></p>
--	---	--	--	---	--

