

Spannzange / *collet* ER25 DIN6499
 Spannbereich / *clamping range*: 1,0 - 16,0

Gewindebohrzange / *tapping collet*
 ET-1-25 M3-M10

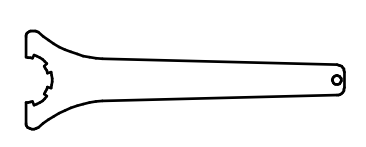

Spannzangenschlüssel
Clamping wrench
 225

Hakenschlüssel
 mit Zapfen
Hook wrench
 with fixed pin
 DIN1810 B 45x50

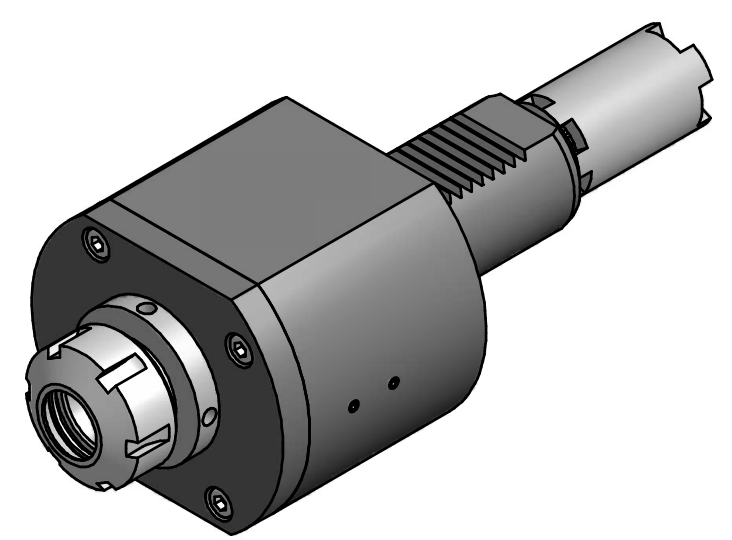

Copyright **EWS Tool Technologies**
 Weitergabe und Vervielfaeltigung dieser Unterlage,
 Verwertung und Mitteilung ihres Inhalts nicht
 gestattet, soweit nicht ausdrecklich zugestanden.
 Zuwiderhandlungen verpflichten zu Schadenersatz.

Bemerkung - <i>Note</i>	Technische Daten - <i>technical data</i> M1 / M2 = 50 / 50 Nm n1 / n2 = 6000 / 6000 1/min i (N1:N2) = 1:1	Benennung - <i>Title</i> Axial Bohr und Fräskopf <i>Axial drilling and milling head</i>	name	date	Technische Aenderungen vorbehalten! <i>Subject to technical modifications!</i>	
			drawing	Theiss		
			EWS Weigete GmbH & Co. KG Maybachstr. 1 D-73066 Uhingen Tel. +49(0)7161/93040-100		Nr. 40.4025HAASSL40	DIN A3
			MNR: 14.1283 IDENT: D-EWS-054925 A		Blatt - page 1 (1)	