

Spannzange / collet ER50 DIN6499
 Spannereich / clamping range: 6,0 - 34,0

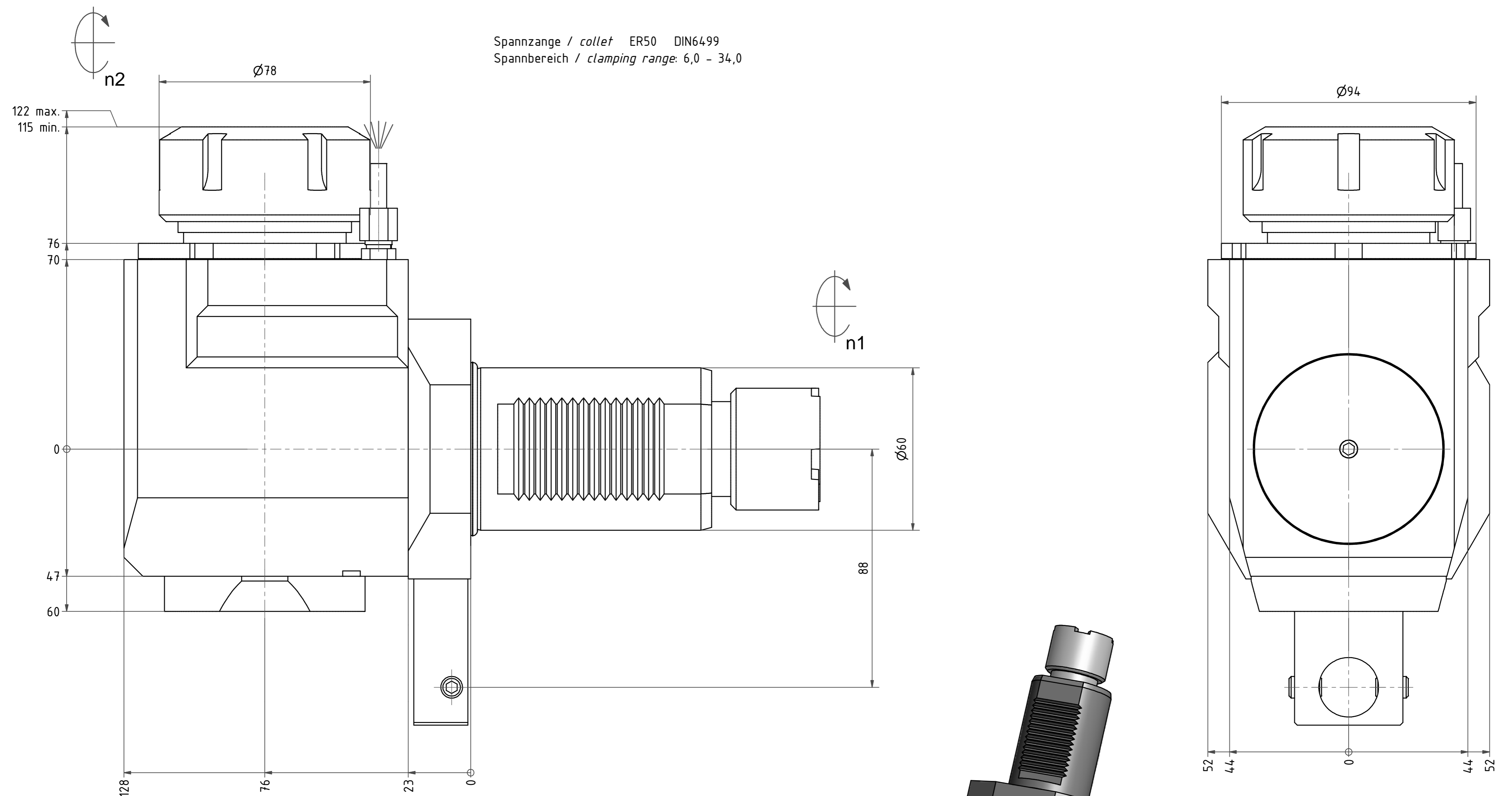

Spannzangenschlüssel
 Clamping wrench
 250

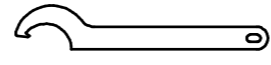

Hakenschlüssel
 mit Nase
 Hook wrench with
 nose end
 DIN1810 A 80x90

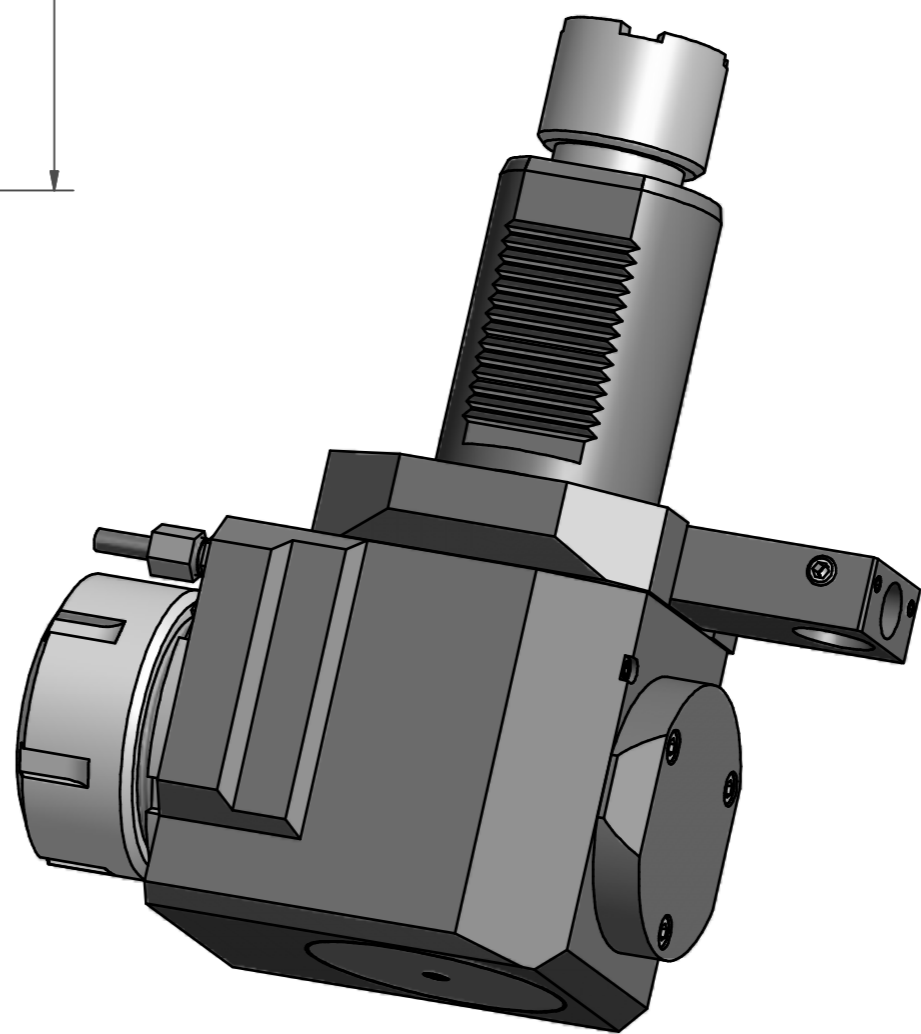

Copyright **EWS**
 Weitergabe und Vervielfältigung dieser Unterlage,
 Verwertung und Mitteilung ihres Inhalts nicht
 gestattet, soweit nicht ausdrücklich zugestanden.
 Zuwiderhandlungen verpflichten zu Schadenersatz.

Benennung - Title	Technische Daten - Technical data		Benennung - Title	name	date	Technische Änderungen vorbehalten! Subject to technical modifications!	
	M ₁ / M ₂ = 160 / 160 Nm n ₁ / n ₂ = 3000 / 3000 1/min i (N ₁ :N ₂) = 1:1						
Benennung - Note			drawing Theiss 16.11.2009		File: D-EWS-081827-ldw		

