

Spannzange / collet ER32 DIN6499  
Spannbereich / clamping range: 2,0 - 20,0

Gewindebohrzange / tapping collet  
ET-1-32 M5-M12

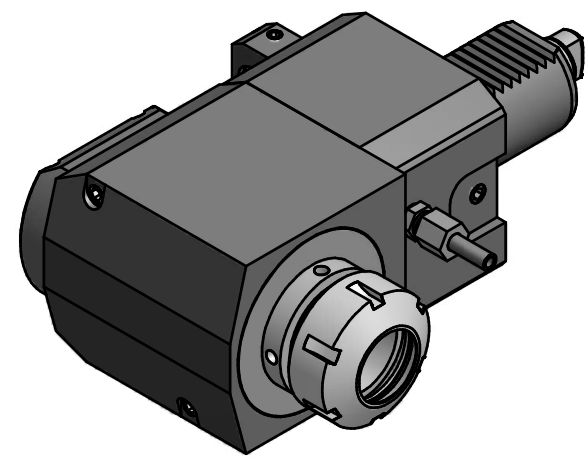

Hakenschlüssel  
mit Zapfen  
Hook wrench  
with fixed pin  
DIN1810 B 45x50

Spannzangenschlüssel  
Clamping wrench  
232

Copyright **EWS Tool Technologies**  
Weitergabe und Vervielfaeltigung dieser Unterlage,  
Verwertung und Mitteilung ihres Inhalts nicht  
gestattet, soweit nicht ausdrecklich zugestanden.  
Zuwiderhandlungen verpflichten zu Schadenersatz.

Bemerkung - Note  Technische Daten - technical data M1 / M2 = 50 / 50 Nm n1 / n2 = 6000 / 6000 1/min i (N1:N2) = 1:1	Benennung - Title <b>Radial Bohr und Fräskopf</b> <i>Radial drilling and milling head</i>	<table border="1"> <tr> <th>name</th> <th>date</th> </tr> <tr> <td>drawing</td> <td>08.02.2007</td> </tr> </table>	name	date	drawing	08.02.2007	Technische Aenderungen vorbehalten! Subject to technical modifications! Nr. <b>60.40321809RGLX100</b> MNR: 110686 IDENT: D-EWS-000803 - Blatt - page 1 (1)
name	date						
drawing	08.02.2007						

