

Spannzange / collet ER32 DIN6499  
 Spannbereich / clamping range: 2,0 - 20,0

Gewindebohrzange / tapping collet  
 ET-1-32 M5-M12

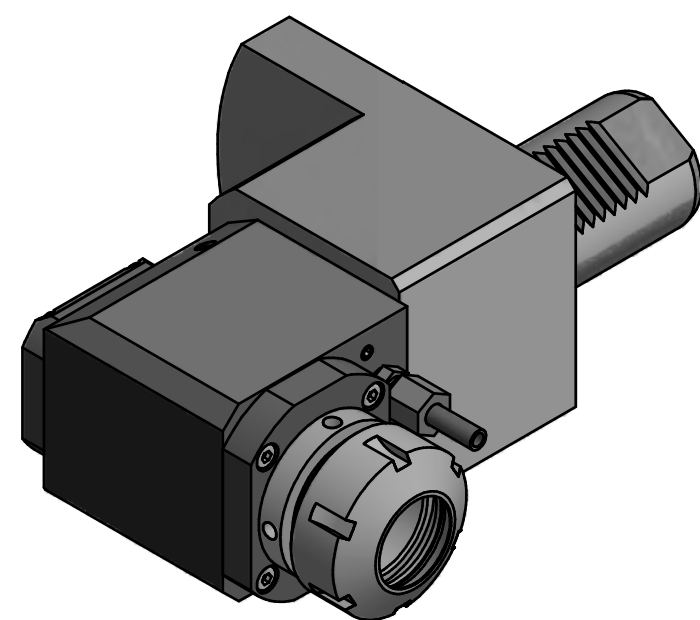

Copyright **EWS Tool Technologies**  
 Weitergabe und Vervielfaeltigung dieser Unterlage,  
 Verwertung und Mitteilung ihres Inhalts nicht  
 gestattet, soweit nicht ausdrecklich zugestanden.  
 Zuwiderhandlungen verpflichten zu Schadenersatz.

Bemerkung - Note
------------------

Technische Daten - technical data	
Weight	= 5.885 [kg]
Torque max. (M1/M2)	= 25 / 25 [Nm]
Speed max. (n1/n2)	= 6000 / 6000 [1/min]
Gear ratio (i)=n1:n2	= 1:1

Benennung - Title	
<b>Radial Bohr und Fräskopf</b>	
<b>Radial drilling and milling head</b>	

	EWS Weigele GmbH & Co. KG Maybachstr. 1 D-73066 Utingen www.ews-tools.de
	Technische Aenderungen vorbehalten! Subject to technical modifications! IDENT: D-EWS-012997
Nr. - No.	60.4032SQT10RX109

MNR. 110481

