

Innen- und Aussenkuehlung  
Inside and outside coolant supply

Schutzrecht angemeldet  
Trademark right applied

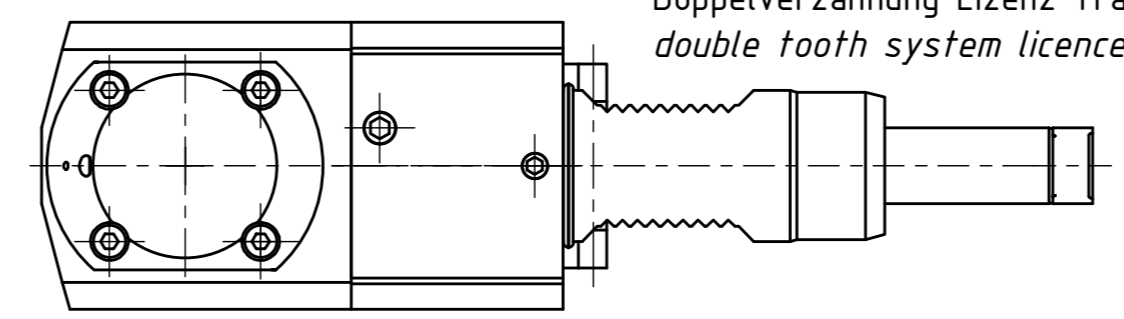

Doppelverzahnung Lizenz Traub  
double tooth system licence Traub

Copyright **EWS Tool Technologies**  
Weitergabe und Vervielfaeltigung dieser Unterlage,  
Verwertung und Mitteilung ihres Inhalts nicht  
gestattet, soweit nicht ausdrecklich zugestanden.  
Zuwiderhandlungen verpflichten zu Schadenersatz.

Bemerkung - Note  
Nicht ohne Kuehlmittel betreiben!  
Not for use without coolant-fluid!

Technische Daten - technical data  
Weight = 7.684 [kg]  
Torque max. (M1/M2) = 50 / 50 [Nm]  
Speed max. (n1/n2) = 6000 / 6000 [1/min]  
Gear ratio (i) = n1:n2 1:1  
Pressure (pmax) = 70 [bar]

Benennung - Title  
Radial Bohr und Fraskopf  
Radial drilling and milling head

**EWS** Tool Technologies  
EWS Weigle GmbH & Co. KG  
Maybachstr. 1  
D-73066 Uhlingen  
www.ews-tools.de  
Technische Aenderungen vorbehalten!  
Subject to technical modifications!  
IDENT: D-EWS-055181  
REV: -/-  
MNR.  
140874

