

min. 62
max. 65,5

SW30
Ø40

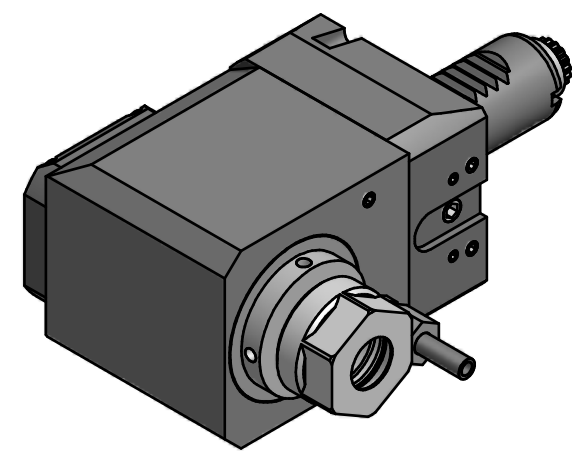

Hakenschlüssel
mit Zapfen
Hook wrench
with fixed pin
DIN1810 B 40x42

Spannzange / collet ER20 DIN6499
Spannbereich / clamping range: 1,0 - 13,0

Gewindebohrzange / tapping collet
ET-1-20 M2-M6

Copyright **EWS Tool Technologies**
Weitergabe und Vervielfaeltigung dieser Unterlage,
Verwertung und Mitteilung ihres Inhalts nicht
gestattet, soweit nicht ausdrecklich zugestanden.
Zuwiderhandlungen verpflichten zu Schadenersatz.

Bemerkung - Note	Technische Daten - technical data M1 / M2 = 25 / 25 Nm n1 / n2 = 8000 / 8000 1/min i (N1:N2) = 1:1	Benennung - Title Radial Bohr und Fräskopf <i>Radial drilling and milling head</i>	<table border="1"> <tr> <th>name</th> <th>date</th> </tr> <tr> <td>drawing</td> <td>19.02.2007</td> </tr> </table>	name	date	drawing	19.02.2007	Technische Aenderungen vorbehalten! Subject to technical modifications! Nr. 60.2520L5480R	 DIN A3
name	date								
drawing	19.02.2007								
MNR: 110664		IDENT: D-EWS-003123 A		Blatt - page 1 (1)					