

EWS-Varia V5

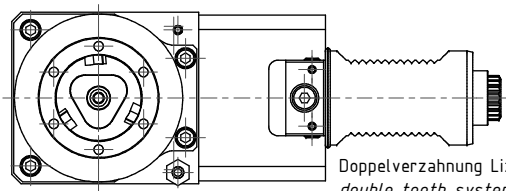

Doppelverzahnung Lizenz Traub  
double tooth system licence Traub

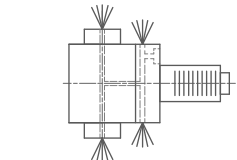
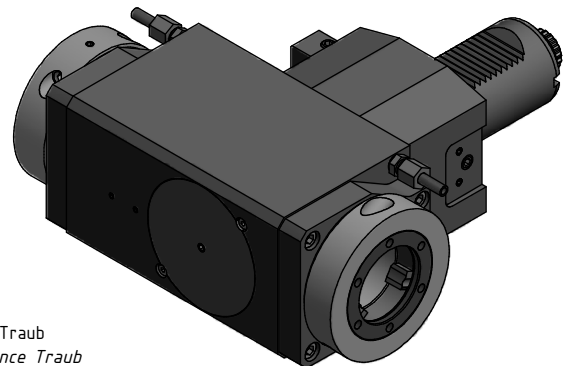

Innen- und Aussenkuehlung / Inside and outside coolant supply  
Kuehlmittelfiltrierung=50µ / coolant filtration=50µ

|  |   |
|--|---|
| Bemerkung - Note<br>Für Trockenlauf geeignet!<br>Use without coolant fluid allowed!<br><b>Schutzrecht angemeldet</b><br><b>Trademark right applied</b> | Technische Daten - Technical data<br>Weight = 16,075 [kg]<br>Torque max. (M1/M2) = 100 / 100 each Sp. [Nm]<br>Speed max. (n1/n2) = 4,000 / 4,000 [1/min]<br>Gear ratio (i1:n1:n2) = 1:1<br>Pressure (pmax) = 70 [bar] |
|--|---|

Benennung - Title  
**Radial Bohr und Fräskopf**  
**Radial drilling and milling head**

|   |  |                    |  |
|---|--|--------------------|--|
| <b>EWS</b><br>Tool Technologies<br>EWS Werkzeug GmbH & Co. KG<br>D-72086 Löhningen<br>www.ews-tool.de | Technische Änderungen vorbehalten!<br>Subject to technical modifications!<br>IDENT: DEWS030224 | REV: -/B<br>140451 |  |
|   | Nr. - No.<br><b>60.50V5D5480RLKDX120</b>   |                    |  |

Copyright **EWS Tool Technologies**  
 Weitergabe und Vervielfältigung dieser Unterlage,  
 Verwertung und Mitteilung ihres Inhalts nicht  
 gestattet, soweit nicht ausdrücklich zugestanden.  
 Zuwiderhandlungen verpflichten zu Schadenersatz.