

Spannzange / collet ER25 DIN6499  
 Spannbereich / clamping range: 1,0 - 16,0

Gewindebohrzange / tapping collet  
 ET-1-25 M3-M10

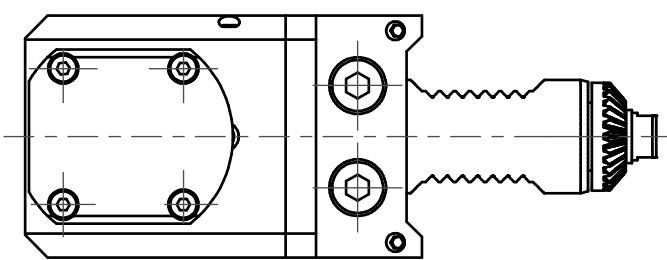

Doppelverzahnung Lizenz Traub  
 double tooth system licence Traub

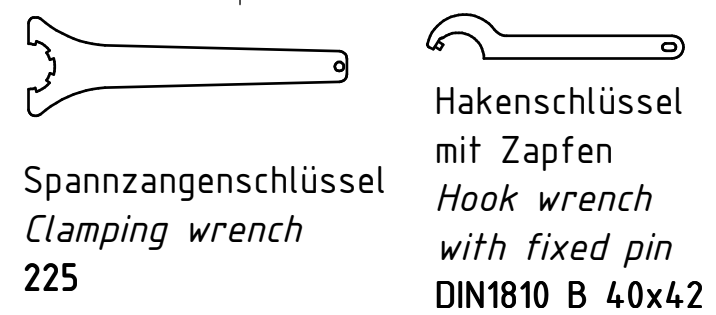
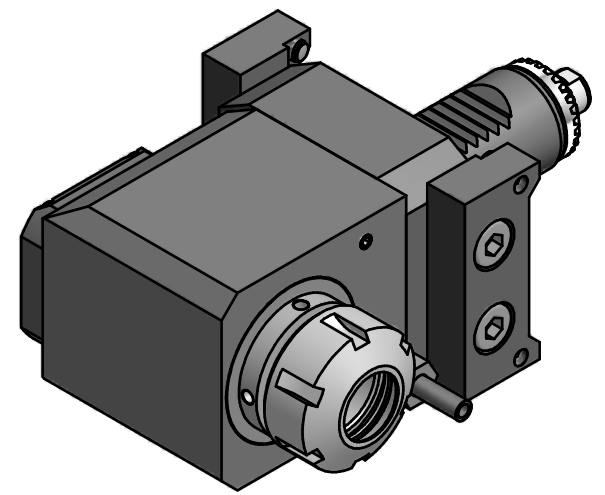

Spannzangenschlüssel  
 Clamping wrench  
 225

Hakenschlüssel  
 mit Zapfen  
 Hook wrench  
 with fixed pin  
 DIN1810 B 40x42

Copyright **EWS Tool Technologies**  
 Weitergabe und Vervielfaeltigung dieser Unterlage,  
 Verwertung und Mitteilung ihres Inhalts nicht  
 gestattet, soweit nicht ausdrecklich zugestanden.  
 Zuwiderhandlungen verpflichten zu Schadenersatz.

Bemerkung - Note	Technische Daten - technical data $M_1 / M_2 = 20 / 40 \text{ Nm}$ $n_1 / n_2 = 6000 / 3000 \text{ 1/min}$ $i (N_1:N_2) = 2:1$	Benennung - Title <b>Radial Bohr und Fräskopf</b> <i>Radial drilling and milling head</i>	name	date	Technische Aenderungen vorbehalten! <i>Subject to technical modifications!</i>	
			drawing	Kratschmann		
			<b>EWS</b> Weigete GmbH & Co. KG Maybachstr. 1 D-73066 Uhingen Tel. +49(0)7161/93040-100		Nr. <b>60.3025TNC65RLI2</b>	DIN A3
			MNR: 109707		IDENT: D-EWS-009844 -	Blatt - page 1 (1)