

Spannzange / collet ER40 DIN6499
 Spannbereich / clamping range: 3,0 - 26,0

Gewindebohrzange / tapping collet
 ET-1-40 M6-M16

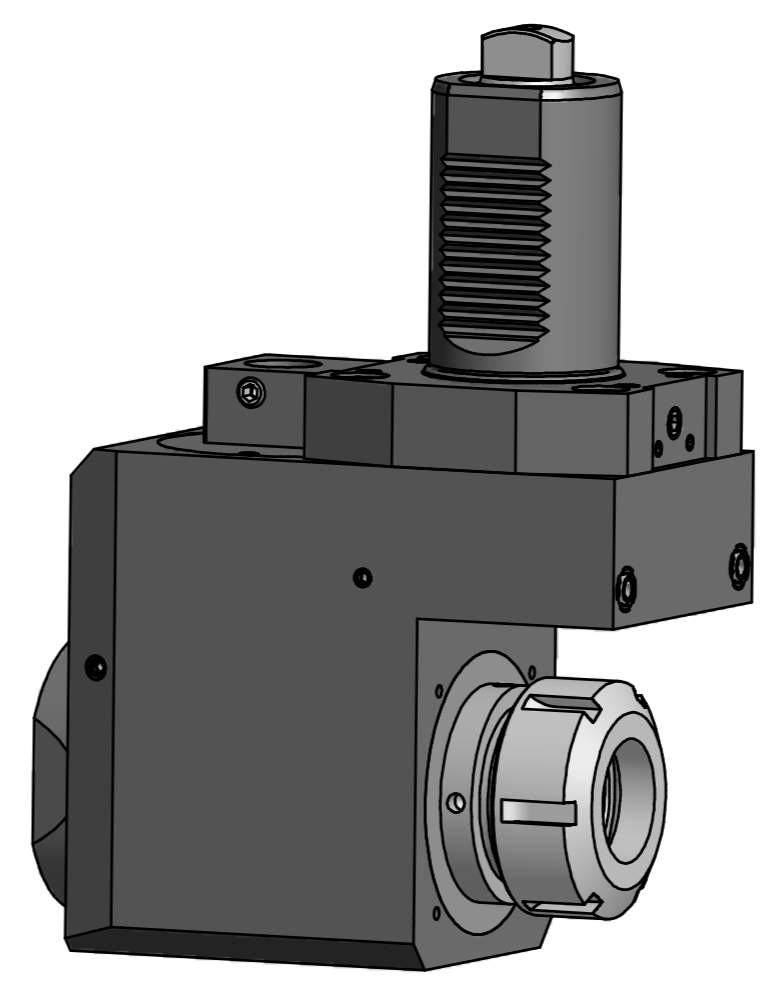
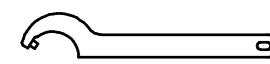
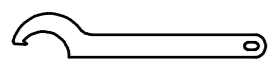

-  Hakenschlüssel mit Zapfen
Hook wrench with fixed pin
DIN1810 B 58x62
-  Hakenschlüssel mit Nase
Hook wrench with nose end
DIN1810 A 58x62

 Hakenschlüssel mit Zapfen
Hook wrench with fixed pin
DIN1810 B 58x62

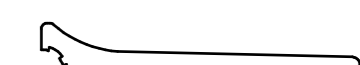
 Spannzangenschlüssel
Clamping wrench
240

Copyright **EWS Tool Technologies**
 Weitergabe und Vervielfältigung dieser Unterlage, Verwertung und Mitteilung ihres Inhalts nicht gestattet, soweit nicht ausdrücklich zugestanden. Zuwiderhandlungen verpflichten zu Schadenersatz.

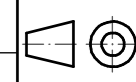
Bemerkung - Note	Technische Daten - Technical data M1 / M2 = 100 / 100 Nm n1 / n2 = 4000 / 4000 1/min i (N1:N2) = 1:1	Benennung - Title Radial Bohr und Fräskopf. zurückges Radial drill. and mill. head offset	<table border="1" style="width: 100%; border-collapse: collapse;"> <tr> <th>name</th> <th>date</th> </tr> <tr> <td>drawing</td> <td>09.02.2007</td> </tr> </table> <p>Technische Änderungen vorbehalten! Subject to technical modifications!</p> <p>Nr. 80.50401809R</p> <p>MNR: 109541 IDENT: D-EWS-001117 - Blatt - page 1 (1)</p>	name	date	drawing	09.02.2007	
name	date							
drawing	09.02.2007							