

Spannzange / collet ER32 DIN6499
 Spannbereich / clamping range: 2,0 - 20,0

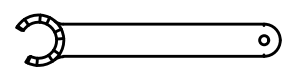

Spannzangenschlüssel für
 innenliegende Mutter
 Clamping wrench for
 internal collet
232AX

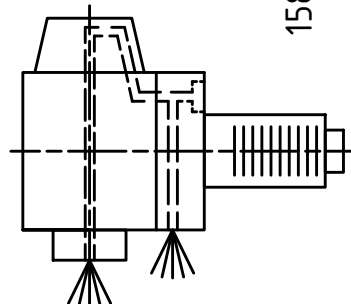
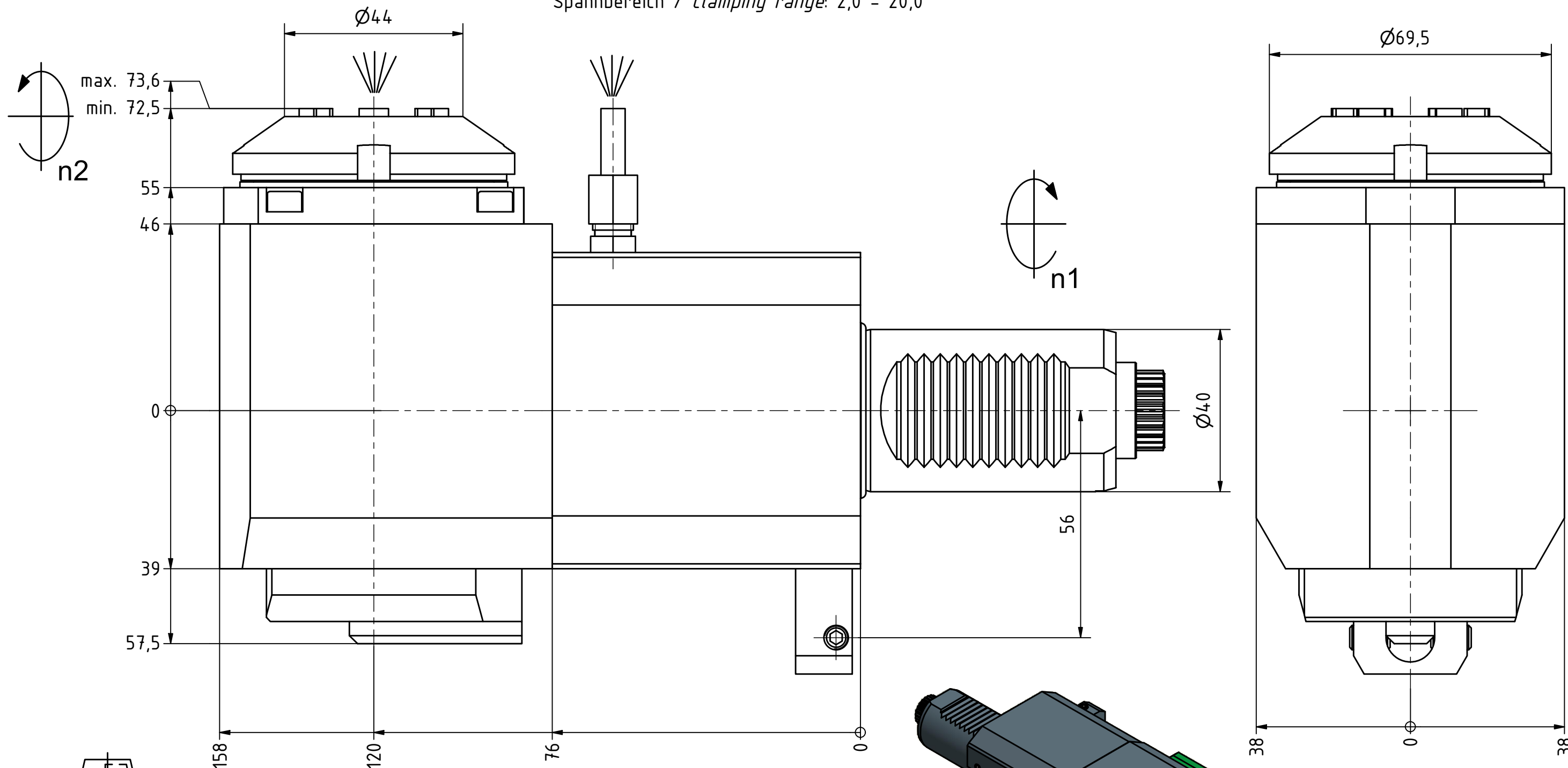
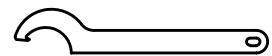

Hakenschlüssel
 mit Nase
 Hook wrench with
 nose end
DIN1810 A 68x75

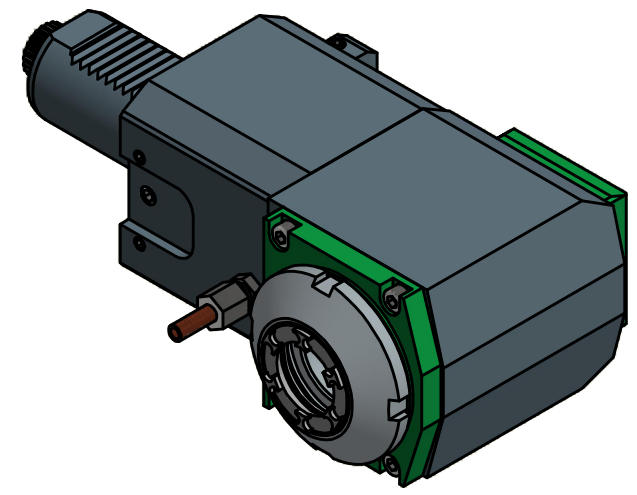

Innen- und Aussenkuehlung / Inside and outside coolant supply
 Kuehlmittelfiltrierung $\le 50\mu$ / coolant filtration $\le 50\mu$

Copyright **EWS Tool Technologies**
 Weitergabe und Vervielfaeltigung dieser Unterlage,
 Verwertung und Mitteilung ihres Inhalts nicht
 gestattet, soweit nicht ausdrecklich zugestanden.
 Zuwiderhandlungen verpflichten zu Schadenersatz.

<p>Bemerkung - Note Für Trockenlauf geeignet! Use without coolant fluid allowed!</p>	<p>Technische Daten - technical data Weight = 7.609 [kg] Torque max. (M1/M2) = 50 / 50 [Nm] Speed max. (n1/n2) = 6000 / 6000 [1/min] Gear ratio (i)=n1:n2 = 1:1 Pressure (pmax) = 70 [bar]</p>	<p>Benennung - Title Radial Bohr und Fräskopf Radial drilling and milling head</p>	<p>EWS Tool Technologies EWS Weigle GmbH & Co. KG Maybachstr. 1 D-73066 UHINGEN www.ews-tools.de</p> <p>Nr. - No. 60.4032LCTXLIKDIM</p>	<p>Technische Aenderungen vorbehalten! Subject to technical modifications! IDENT: D-EWS-051872</p>	<p>REV: -/A MNR. 140399</p>	<p>QR</p>
--	---	--	--	--	--	------------------