

Capto C5-Aufnahme
Capto C5-Adaptor

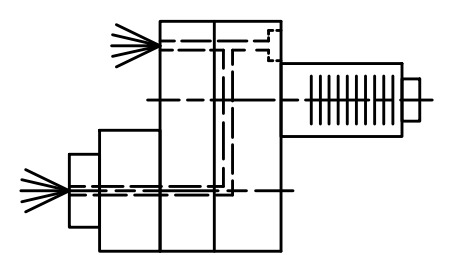
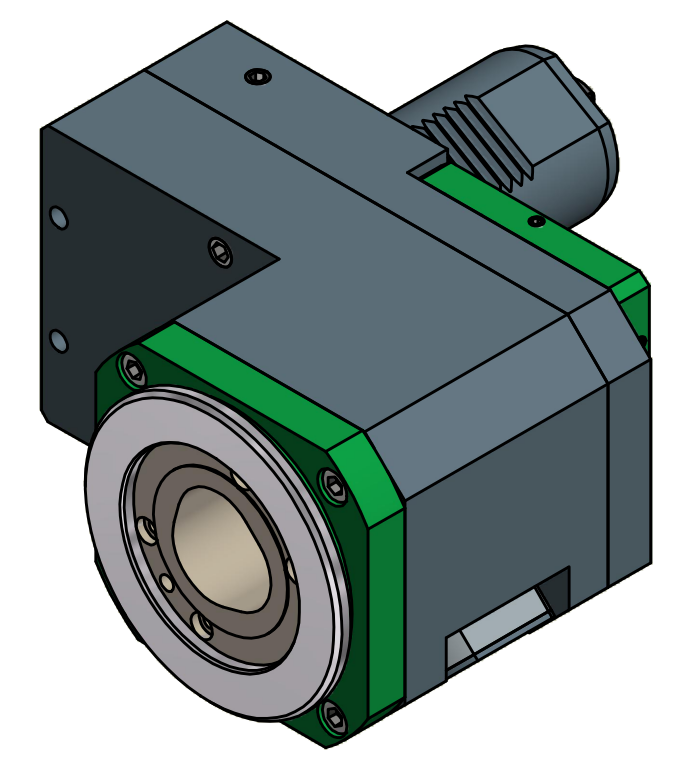

Innen- und Aussenkuehlung / Inside and outside coolant supply
Kein Trockenlauf / No dry run
Kuehlmittelfiltrierung 50μ / coolant filtration 50μ

Bemerkung - Note Nicht ohne Kuehlmittel betreiben! Not for use without coolant-fluid!	Technische Daten - technical data
	Weight = 11,999 [kg]
	Torque max. (M1/M2) = 100 / 100 [Nm]
	Speed max. (n1/n2) = 4000 / 4000 [1/min]
	Gear ratio (i)=n1:n2 = 1:1
Pressure (pmax) = 70 [bar]	

Benennung - Title
Axial Bohr u. Fräskopf achsversetzt
Ax. drill. and mill. head offset

EWS Tool Technologies <small>EWS Weigle GmbH & Co. KG Maybachstr. 1 D-73066 Uhlingen www.ews-tool.de</small>	Technische Aenderungen vorbehalten! Subject to technical modifications! IDENT: DEWS143429	MNR. REV: -/B
	Nr. - No. 50.50C5SQT28RIK	109195

Copyright **EWS Tool Technologies**
 Weitergabe und Vervielfaeltigung dieser Unterlage,
 Verwertung und Mitteilung ihres Inhalts nicht
 gestattet, soweit nicht ausdrecklich zugestanden.
 Zuwiderhandlungen verpflichten zu Schadenersatz.

