

Doppelverzahnung Lizenz Traub  
*double tooth system licence Traub*

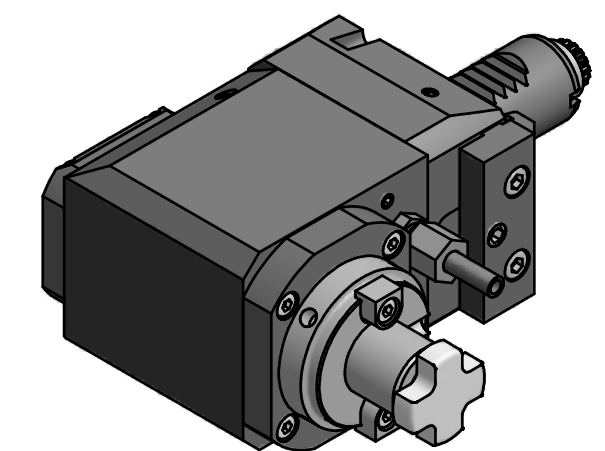

Copyright **EWS Tool Technologies**  
 Weitergabe und Vervielfaeltigung dieser Unterlage,  
 Verwertung und Mitteilung ihres Inhalts nicht  
 gestattet, soweit nicht ausdrecklich zugestanden.  
 Zuwiderhandlungen verpflichten zu Schadenersatz.

Bemerkung - Note	Technische Daten - technical data	Benennung - Title	name	date	Technische Aenderungen vorbehalten! Subject to technical modifications!	
	M1 / M2 = 25 / 25 Nm n1 / n2 = 8000 / 8000 1/min i (N1:N2) = 1:1	<b>Radial Fräskopf</b> <i>Radial milling head</i>	drawing	CAD		
			Weigele GmbH & Co. KG Maybachstr. 1 D-73066 UHINGEN Tel. +49(0)7161/93040-10		File: 62.2522E332RL_OUT.idw	Blatt - page 1 (1)