

max. Fraeser Ø80

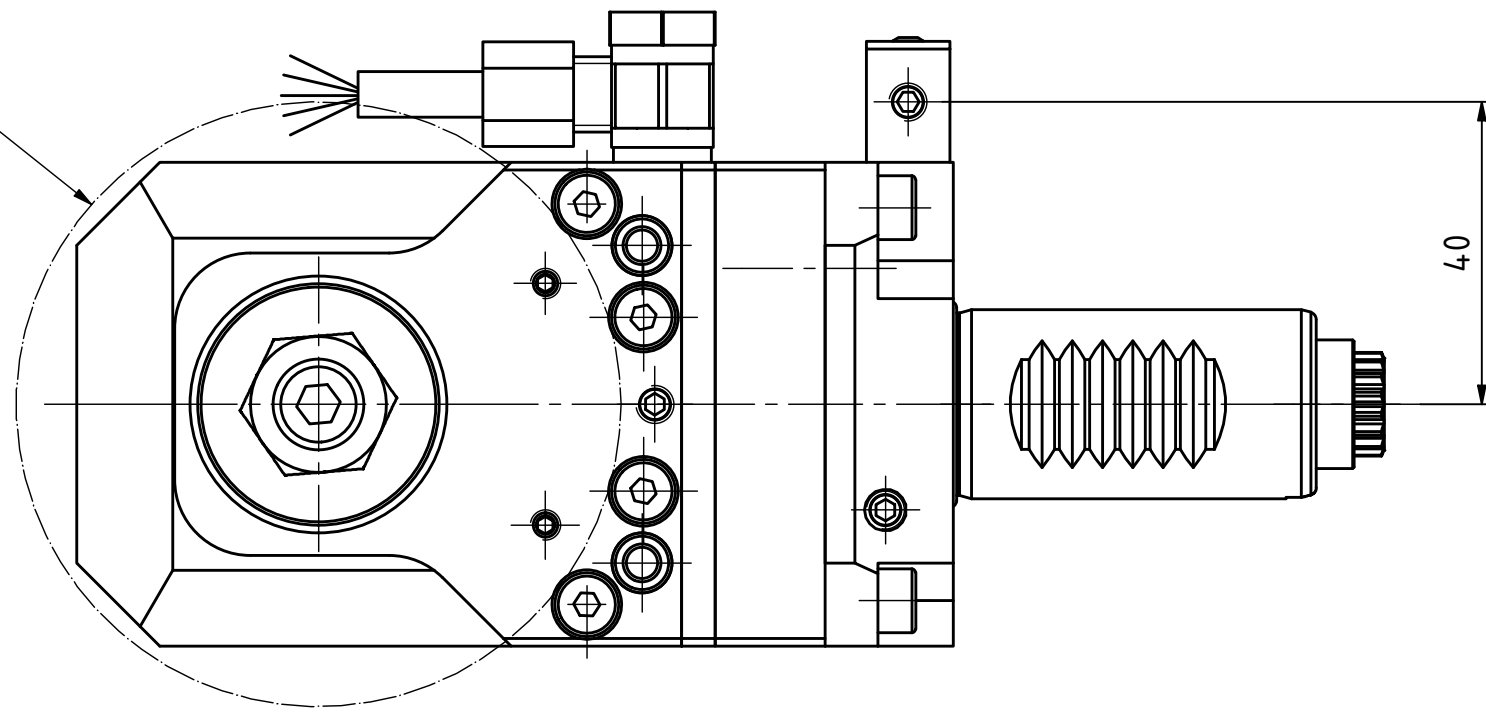

40

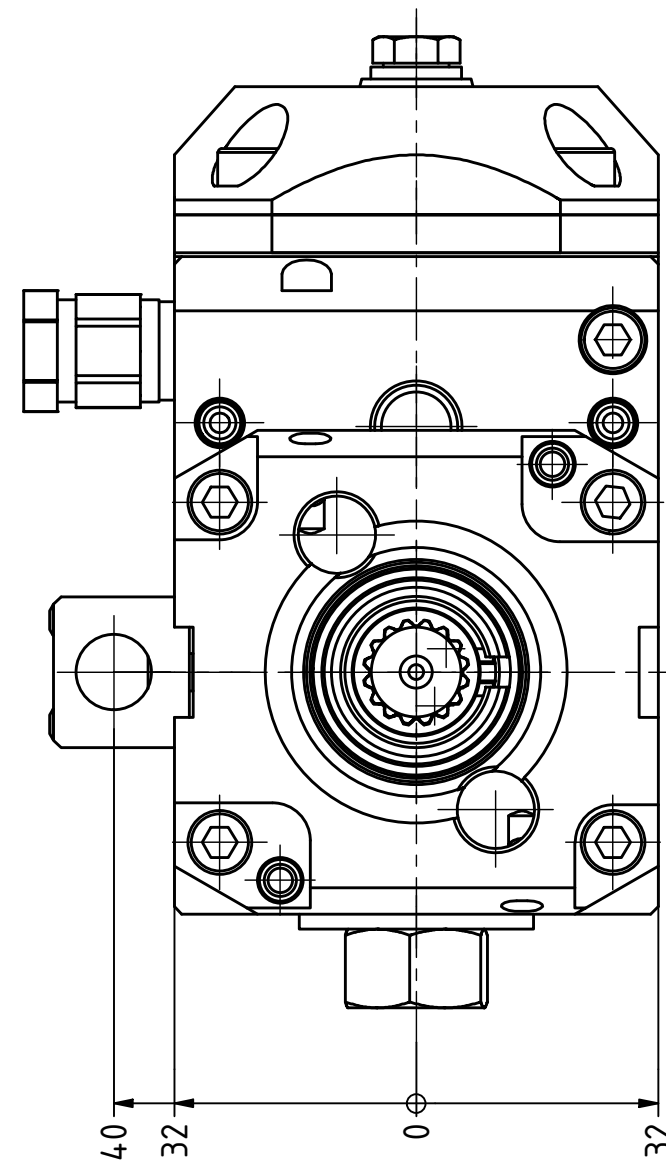

40 32 0 32

Fraeserwelle austauschbar  
Spindle removable

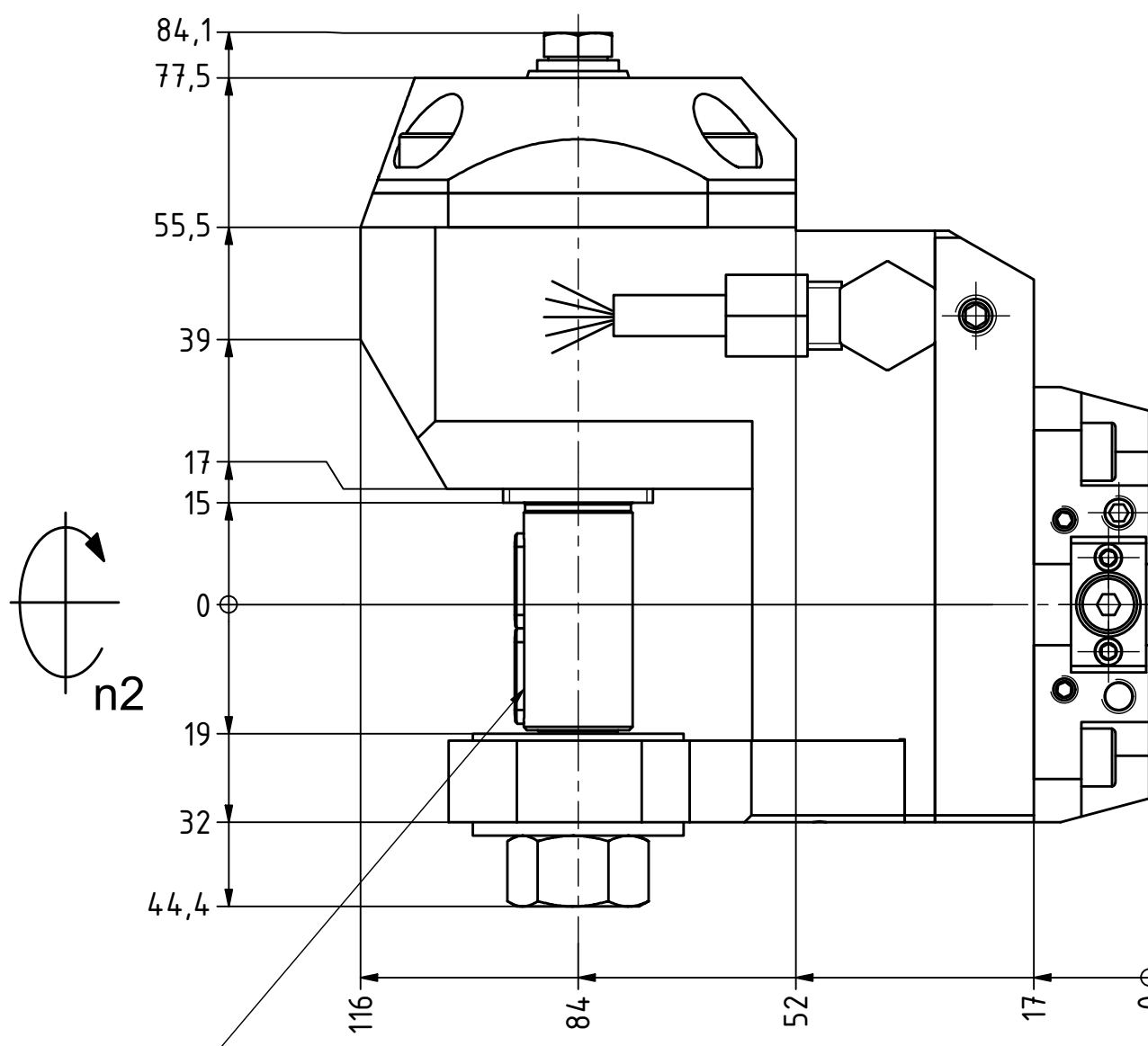

84,1  
77,5  
55,5  
39  
17  
15  
0  
19  
32  
44,4

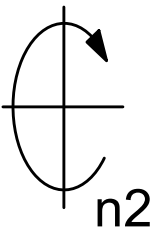

n2

116 84 52 17 0

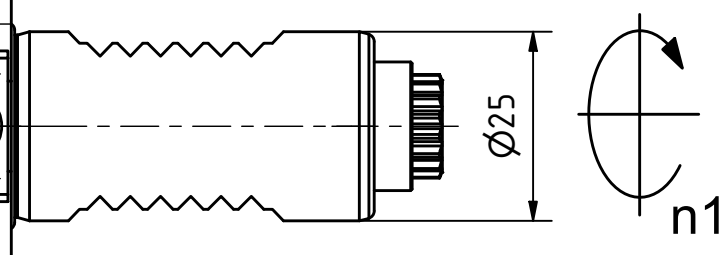

Doppelverzahnung Lizenz Traub  
double tooth system licence Traub

Ø25

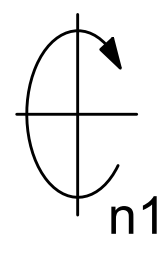

n1

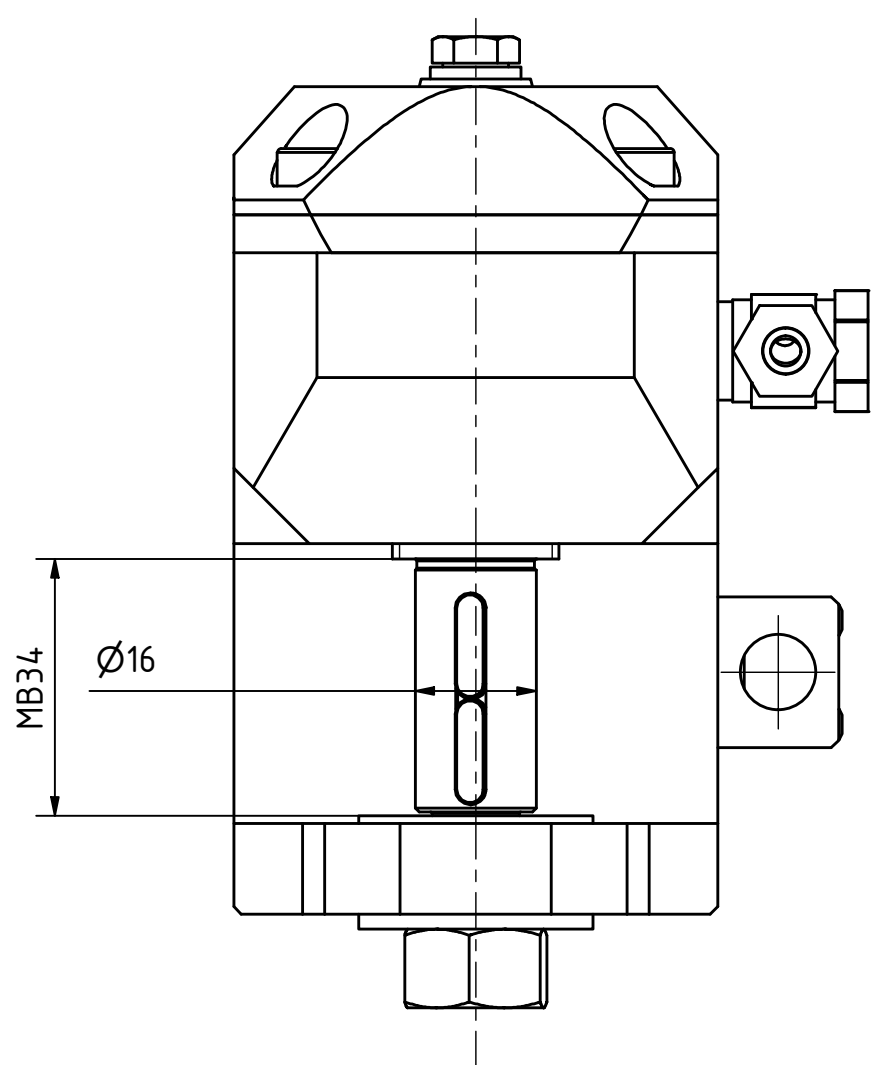

MB34

Ø16

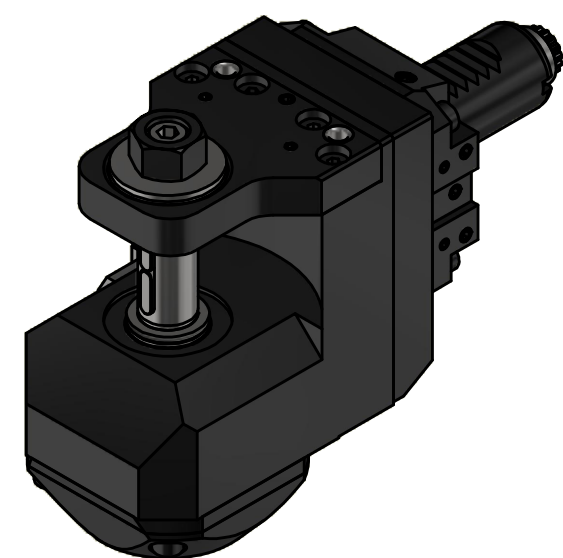

Copyright **EWS Tool Technologies**  
Weitergabe und Vervielfältigung dieser Unterlage,  
Verwertung und Mitteilung ihres Inhalts nicht  
gestattet, soweit nicht ausdrücklich zugestanden.  
Zuwendungen verpflichten zu Schadenersatz.

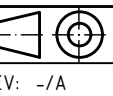
Bemerkung - Note	Technische Daten - technical data <b>Weight</b> = 3.683 [kg] <b>Torque max.</b> (M1/M2) = 20 / 60 [Nm] <b>Speed max.</b> (n1/n2) = 6000 / 2000 [1/min] <b>Gear ratio</b> (i)=n1:n2 = 3:1	Benennung - Title <b>Scheibenfräserkopf</b> <b>Radial saw milling head</b>	 <b>EWS</b> Weigle GmbH & Co. KG Maybachstr. 1 D-73066 Uhlingen www.ews-tools.de Technische Änderungen vorbehalten! Subject to technical modifications! IDENT: D-EWS-051473 Nr. - No. <b>64.25165480RLI3-S02</b>	 REV: -/A MNR. <b>140165</b> <b>QR</b>
------------------	------------------------------------------------------------------------------------------------------------------------------------------------------------------------------------------------------	----------------------------------------------------------------------------------	-------------------------------------------------------------------------------------------------------------------------------------------------------------------------------------------------------------------------------------------------------------------------------------------------------------------------------	--------------------------------------------------------------------------------------------------------------------------------------