

Bei Sternrevolver muss der zweite Pin entfernt werden !
 On star turret, the secondary pin must be pulled out !

Doppelverzahnung Lizenz Traub
 double tooth system licence Traub

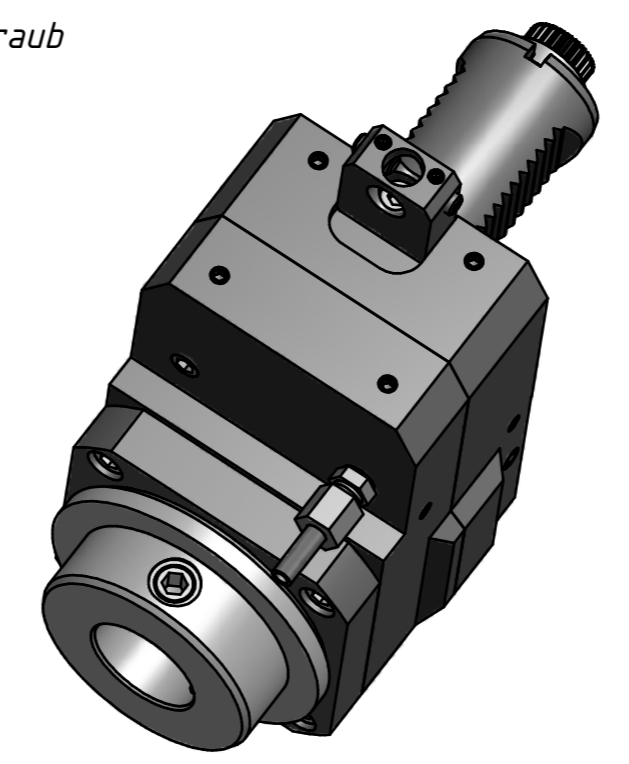
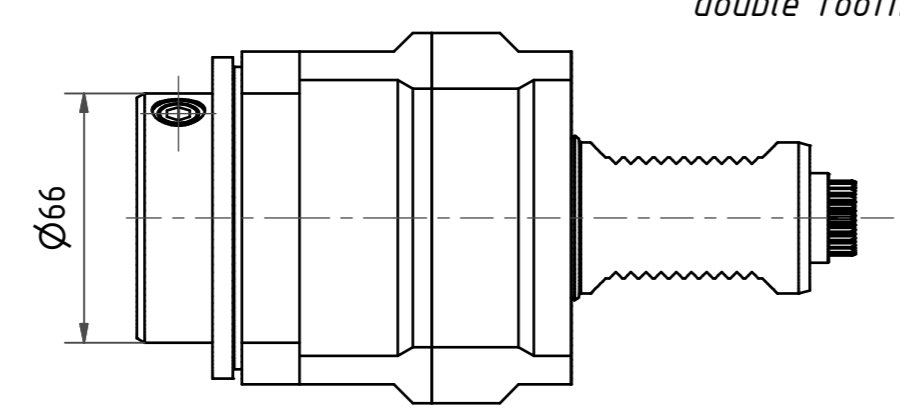

Innen- und Aussenkuehlung / Inside and outside coolant supply
 Kein Trockenlauf / No dry run
 Kuehlmittelfiltrierung 50μ / coolant filtration 50μ

Bemerkung - Note
 Nicht ohne Kuehlmittel betreiben!
 Not for use without coolant-fluid!
 mit Kegelrollenlager
 with taper roller bearing

Technische Daten - Technical data
 $M_1 / M_2 = 40 / 120 \text{ Nm}$
 $n_1 / n_2 = 6000 / 2000 \text{ 1/min}$
 $i (N_1:N_2) = 3:1$
 $p_{max} = 70 \text{ bar}$

Benennung - Title
 Axial Bohr u. Fräskopf achsversetzt
 Ax. drill. and mill. head offset

name	date
Schmid	07.12.2007

Technische Änderungen vorbehalten! Subject to technical modifications!	
Nr.	50.4032WNKRCTXRLIK13
MNR:	140530
IDENT:	D-EWS-054033 - Blatt - page 1 (1)

