

Fraeserwelle austauschbar  
spindle removable

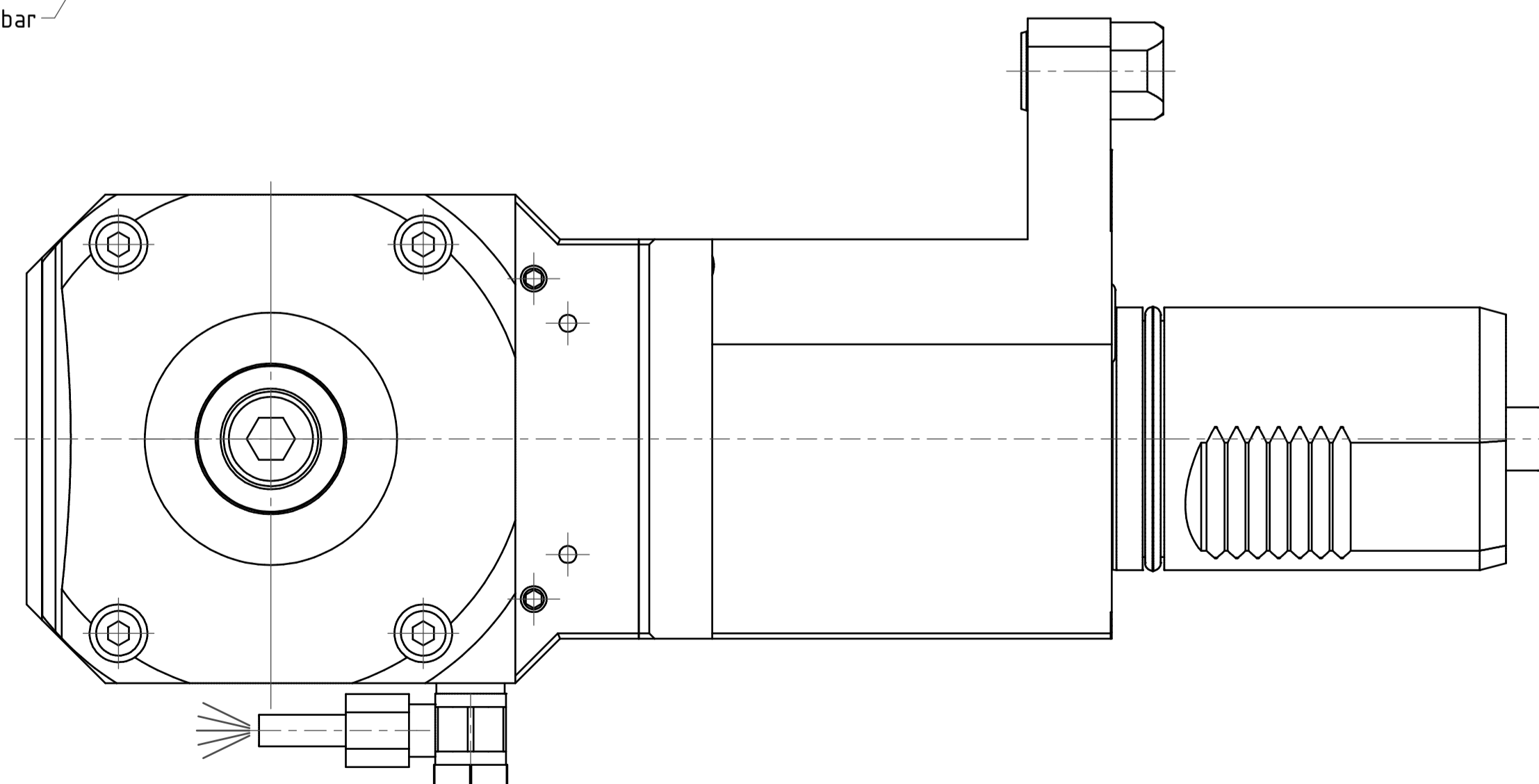
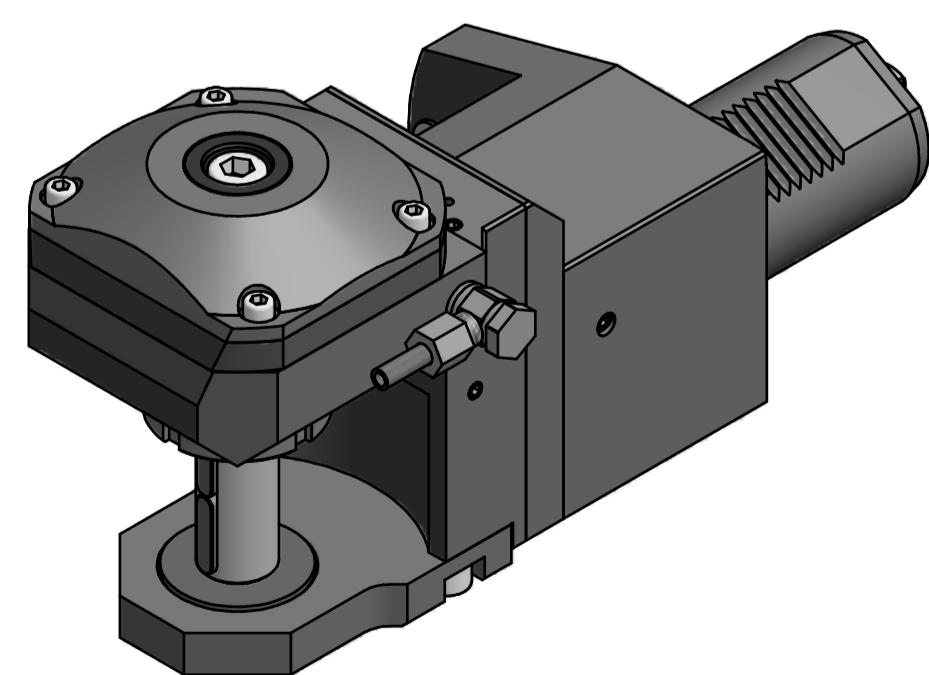
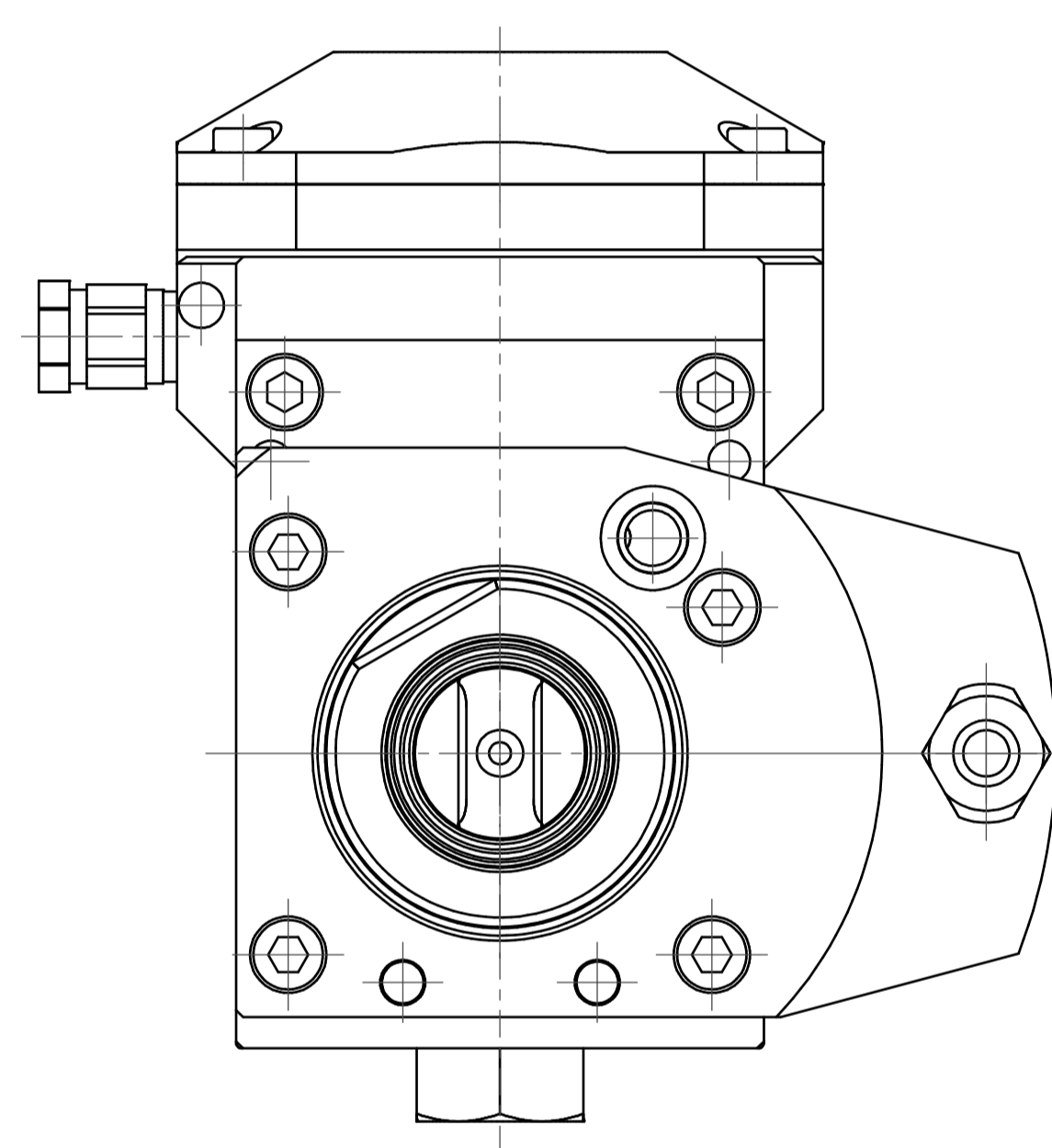
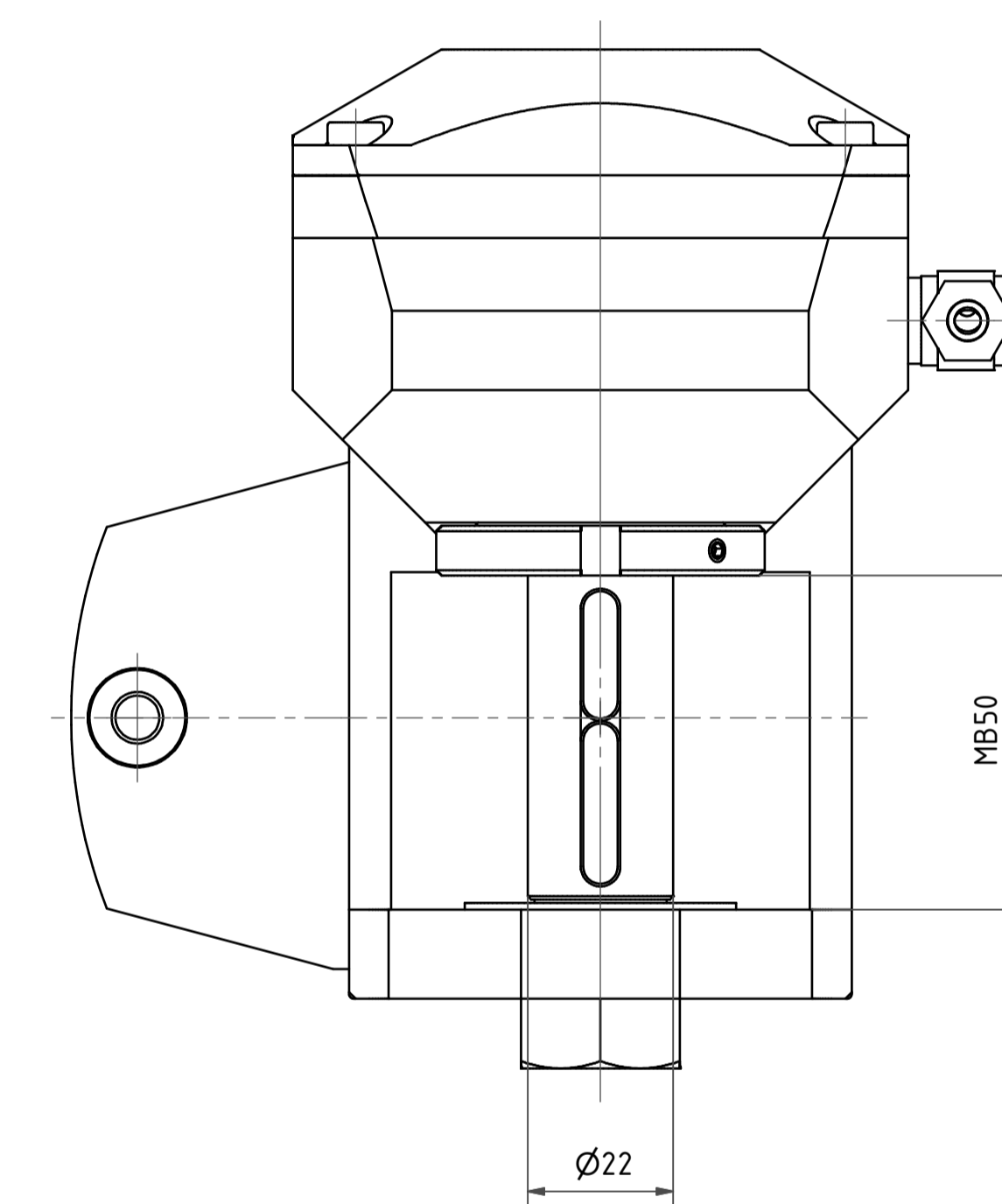

Bemerkung - Note

Technische Daten - technical data  
 Weight = 11.234 [kg]  
 Torque max. (M1/M2) = 50 / 150 [Nm]  
 Speed max. (n1/n2) = 6000 / 2000 [1/min]  
 Gear ratio (i)=n1:n2 = 3:1

Benennung - Title

Scheibenfräserkopf  
 Radial saw milling head

**EWS** Tool Technologies  
 DWS Werkzeug GmbH & Co. KG  
 Hauptstr. 1  
 67206 Keltern  
 www.ews-tool.de

Technische Änderungen vorbehalten!  
 Subject to technical modifications!  
 IDENT: D-EWS-194-312

REV: -/-  
 MBR:  
 139824



Copyright EWS Tool Technologies  
 Weitergabe und Vervielfältigung dieser Unterlage,  
 Verwertung und Mitteilung ihres Inhalts nicht  
 gestattet, soweit nicht ausdrücklich zugestanden.  
 Zuwiderhandlungen verpflichten zu Schadenersatz.