

Spannzange / collet ER25 DIN6499
 Spannereich / clamping range: 1,0 - 16,0

Gewindebohrzange / tapping collet
 ET-1-25 M3-M10

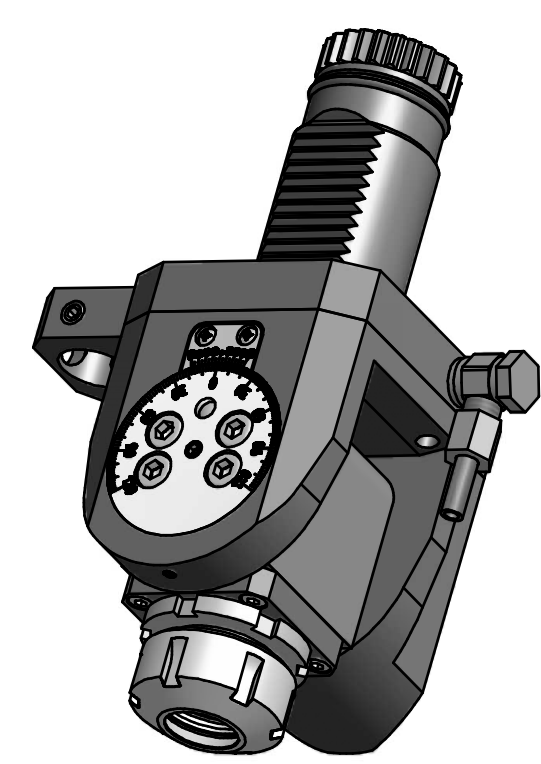
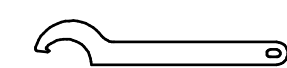
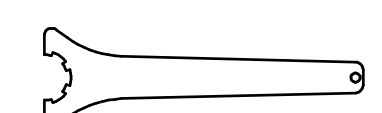

- 
 Hakenschlüssel
 mit Nase
 Hook wrench with
 nose end
 DIN1810 A 45x50
- 
 Spannzangenschlüssel
 Clamping wrench
 225

Copyright **EWS Tool Technologies**
 Weitergabe und Vervielfältigung dieser Unterlage,
 Verwertung und Mitteilung ihres Inhalts nicht
 gestattet, soweit nicht ausdrücklich zugestanden.
 Zuwiderhandlungen verpflichten zu Schadenersatz.

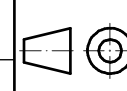
Bemerkung - Note	Technische Daten - technical data M1 / M2 = 20 / 20 Nm n1 / n2 = 6000 / 6000 1/min i (N1:N2) = 1:1	Benennung - Title <h2 style="margin: 0;">Schwenkkopf</h2> <h3 style="margin: 0;">Swivel head</h3>	<table border="1" style="width: 100%; border-collapse: collapse;"> <tr> <td style="width: 50%; text-align: center;">name</td> <td style="width: 50%; text-align: center;">date</td> </tr> <tr> <td style="text-align: center;">drawing</td> <td style="text-align: center;">11.08.2006</td> </tr> </table> <div style="font-size: small; margin-top: 5px;"> EWS Weigle GmbH & Co. KG Maybachstr. 1 D-73066 Uhingen Tel. +49(0)7161/93040-10 </div>	name	date	drawing	11.08.2006	Technische Aenderungen vorbehalten! Subject to technical modifications! Nr. <h2 style="margin: 0;">63.4025TNA480</h2> File: 63.4025TNA480_OUT.idw	 DIN A3
name	date								
drawing	11.08.2006								
			Blatt - page 1 (1)						