

Spannzange / collet ER25 DIN6499
 Spannungsbereich / clamping range: 1,0 - 16,0

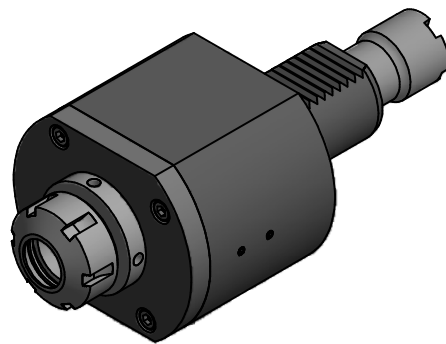

Hakenschlüssel
 mit Zapfen
 Hook wrench
 with fixed pin
 DIN1810 B 45x50

Spannzangenschlüssel
 Clamping wrench
 225

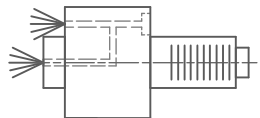

Innen- und Aussenkuehlung / Inside and outside coolant supply
 Kein Trockenlauf / No dry run
 Kuehlmittelfiltrierung-50 μ / coolant filtration-50 μ

Copyright **EWS Tool Technologies**
 Weitergabe und Vervielfaeltigung dieser Unterlage,
 Verwertung und Mitteilung ihres Inhalts nicht
 gestattet, soweit nicht ausdruercklich zugestanden.
 Zuwiderhandlungen verpflichten zu Schadenersatz.

<p>Bemerkung - Note</p> <p>Nicht ohne Kuehlmittel betreiben! <i>Not for use without coolant-fluid!</i></p>	<p>Technische Daten - technical data</p> <p>Weight = 4.092 [kg] Torque max. (M1/M2) = 50 / 50 [Nm] Speed max. (n1/n2) = 6000 / 6000 [1/min] Gear ratio (i)=n1:n2 = 1:1 Pressure (pmax) = 25 [bar]</p>	<p>Benennung - Title</p> <p>Axial Bohr und Fräskopf <i>Axial drilling and milling head</i></p>	<p>EWS Tool Technologies <small>EWS Weigelt GmbH & Co. KG Maybachstr. 1 D-73066 Uhlingen www.ews-tools.de</small></p> <p>Nr. - No. 40.4025LB15IK</p>	<p>Technische Aenderungen vorbehalten! <i>Subject to technical modifications!</i></p> <p>IDENT: DEWS04.3228</p>	<p>REV: -/A</p> <p>MNR. 108246</p>	<p>QR</p>
---	---	--	--	--	--	-----------