

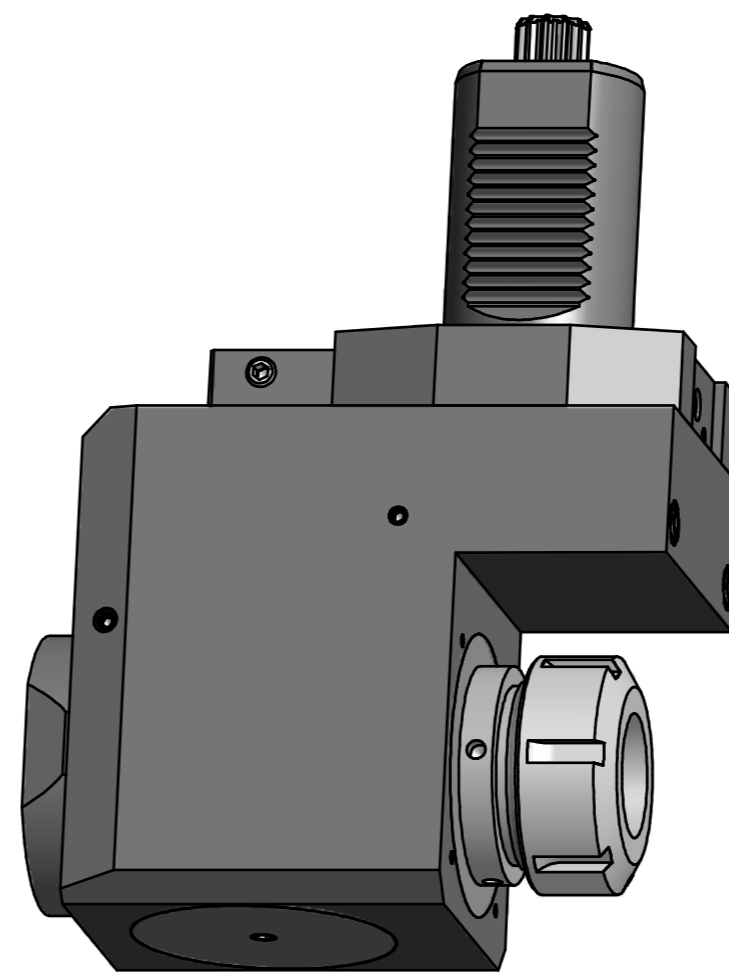

Spannzange / collet ER40 DIN6499  
Spannbereich / clamping range: 3,0 - 26,0

Gewindebohrzange / tapping collet  
ET-1-40 M6-M16



  
Hakenschlüssel  
mit Zapfen  
Hook wrench  
with fixed pin  
DIN1810 B 58x62

  
Spannzangenschlüssel  
Clamping wrench  
240

Copyright **EWS Tool Technologies**  
Weitergabe und Vervielfältigung dieser Unterlage,  
Verwertung und Mitteilung ihres Inhalts nicht  
gestattet, soweit nicht ausdrücklich zugestanden.  
Zuwendungen verpflichten zu Schadenersatz.

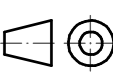
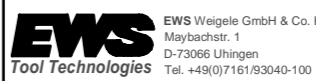
Bemerkung - Note	Technische Daten - technical data M <sub>1</sub> / M <sub>2</sub> = 100 / 100 Nm n <sub>1</sub> / n <sub>2</sub> = 4000 / 4000 1/min i (N <sub>1</sub> :N <sub>2</sub> ) = 1:1	Benennung - Title <b>Radial Bohr und Fräskopf. zurückges</b> <b>Radial drill. and mill. head offset</b>	name	date	Technische Änderungen vorbehalten! Subject to technical modifications!	 DIN A2	
			drawing	16.02.2007			Nr. <b>80.50405482R</b>
			 EWS Werkzeug GmbH & Co. KG Maybachstr. 1 D-73066 Ulm/lingen Tel. +49(0)7161/93040-100		MNR: 108227	IDENT: D-EWS-002661 -	Blatt - page 1 (1)